



# CW COMPACT HEIGHT MEDIUM

MODEL	F <sub>0</sub>	Ø	S	L1	Pmax	Charge Port		
CW 170 V1	170	Ø19	7 - 125	44 - 285	180	M6	X	X
CW 320 V1	320	Ø25	7 - 125	44 - 285	180	M6	X	X
CW 350 V1	350	Ø32	10 - 125	50 - 280	180	M6	✓	✓
CW 500 V1	500	Ø38	10 - 125	50 - 280	150	M6	✓	✓
CW 750 V1	750	Ø45	10 - 125	52 - 282	150	M6	✓	✓
CWC 750 V2	750	Ø45	10 - 125	62 - 292	150	G1/8"	✓	✓
CW 1000 V2	1000	Ø50	10 - 125	58 - 288	150	M6	✓	✓
CWC 1000 V2	1000	Ø50	10 - 125	68 - 298	150	G1/8"	✓	✓
CW 1500 V1	1500	Ø63	13 - 125	70 - 294	150	M6	✓	✓
CWC 1500	1500	Ø63	13 - 125	80 - 304	150	G1/8"	✓	✓
CW 2400 V1	2400	Ø75	13 - 125	71 - 295	150	M6	✓	✓
CWC 2400 V2	2400	Ø75	13 - 125	81 - 305	150	G1/8"	✓	✓
CW 4200 V1	4200	Ø95	16 - 125	90 - 308	150	G1/8"	✓	✓
CW 6600	6600	Ø120	16 - 125	100 - 318	150	G1/8"	✓	✓
CW 9500	9500	Ø150	19 - 125	116 - 328	150	G1/8"	✓	✓
CW 11800	11800	Ø150	19 - 125	116 - 328	150	G1/8"	✓	✓
CW 20000	20000	Ø195	19 - 125	148 - 360	150	G1/8"	✓	✓

		50		50	50	50	50	50
		Ø50		Ø50	Ø50	Ø50	Ø50	Ø50
		L1=138 L1=152 L1=152		L1=138 L1=150 L1=150	L1=170 L1=185 L1=195	L1=195	L1=165 L1=175	L1=220
		1000 1000 1000		1000 1000 750	750 1000 1000	750	1700 2000	1800
MODEL	X	CW 1000 KZ 1000 KT 1000	X	CT 1000 CK 1000 FD 750	GN 750 CM 1000 CD 1000	AG 750	CPH 1700 CP 2000	CS 1800
SERIES	MINI	COMPACT HEIGHT	THREADED	LOW PROFILE	HEAVY DUTY	ISO	HEAVY LOAD	POWER COMPACT STROKE

# CW 170 V1

Compact Height

BMW	B2 4005		
MB	B8 3180 220 000 004		
VW	39D 997		

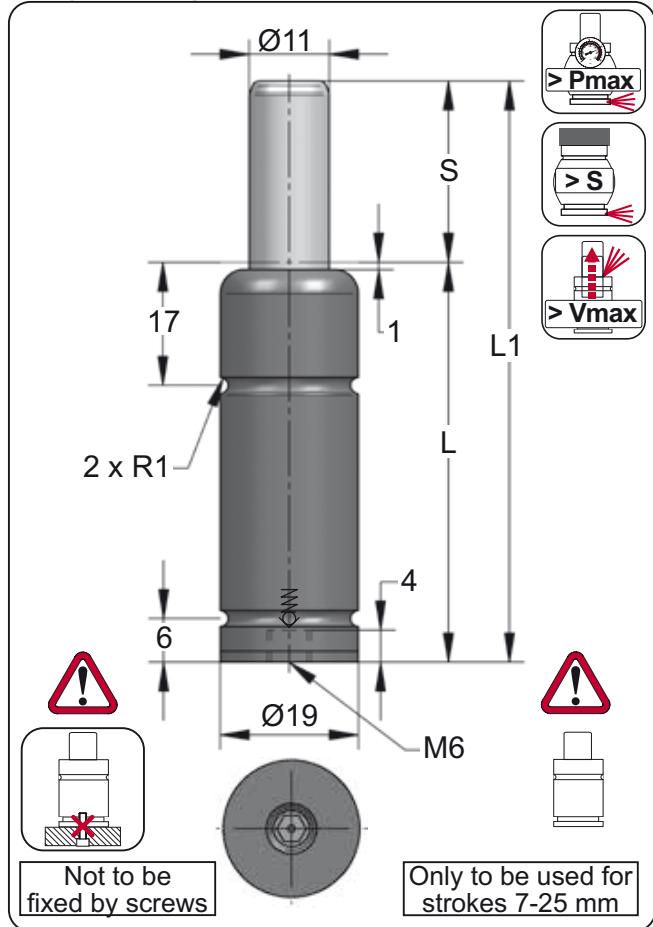

Not to be fixed by screws

Only to be used for strokes 7-25 mm

ORDER	S (mm)	L1 ±0.25 (mm)	L (mm)	Kg.
CW 170 007 V1	7	44	37	0.08
CW 170 010 V1	10	50	40	0.08
CW 170 013 V1	13	56	43	0.08
CW 170 015 V1	15	60	45	0.09
CW 170 019 V1	19	68	49	0.09
CW 170 025 V1	25	80	55	0.10
CW 170 032 V1	32	94	62	0.11
CW 170 038 V1	38	106	68	0.12
CW 170 050 V1	50	130	80	0.13
CW 170 063 V1	63	156	93	0.15
CW 170 075 V1	75	185	110	0.16
CW 170 080 V1	80	195	115	0.17
CW 170 100 V1	100	235	135	0.20
CW 170 125 V1	125	285	160	0.23



CODE	Image	Pressure		Force	
		bar	psi	daN	daN
CW 170 050 V1		180	2610	170	295
-----		-----	-----	-----	-----

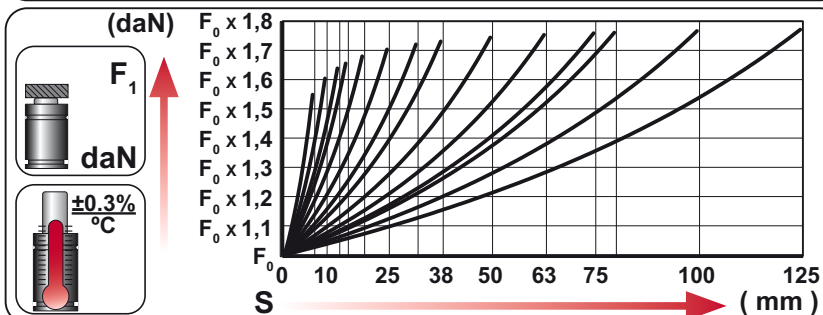
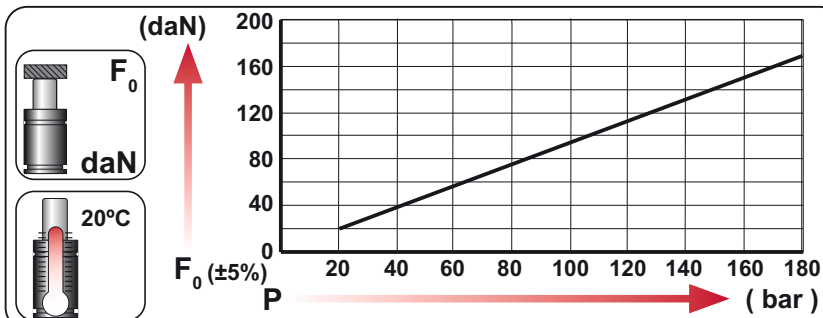

VDI 3003 **EQUIPPED WITH VDI - SAFETY**

Language	Order	Force (F0)	Stroke (S)
ENG	ORDER	daN	mm
DEU	BESTELLUNG		
FRA	COMMANDE		
ITA	ORDINE		
ESP	PEDIDO		
POR	PEDIDO		
<b>CW 170 050 V1</b>		<b>170</b>	<b>50</b>

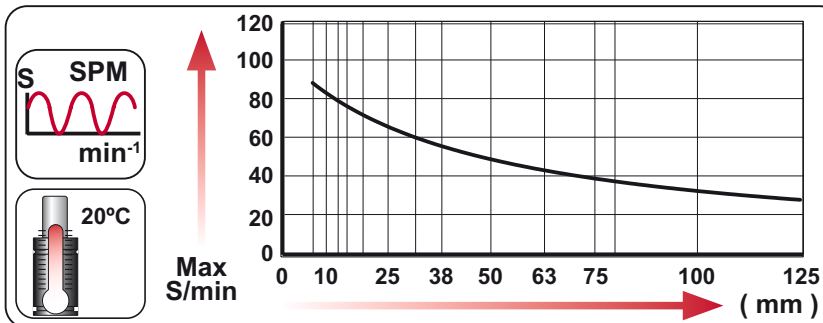

--	--	--	--	--	--

N <sub>2</sub>	Smax < 90%	Vmax 1,6 m/s	bar psi	bar psi	°C °F	°C °F	
			20 290	180 2610	0 32	80 176	



# CW 170 V1 MOUNTS

Compact Height

## A14-019

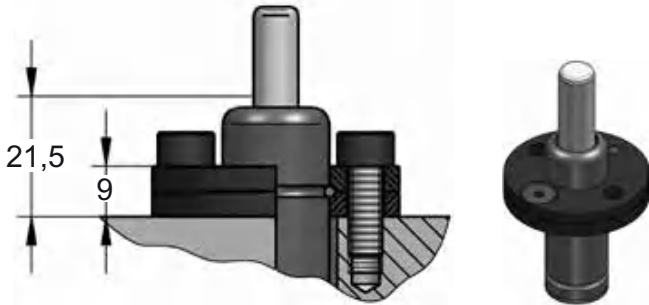
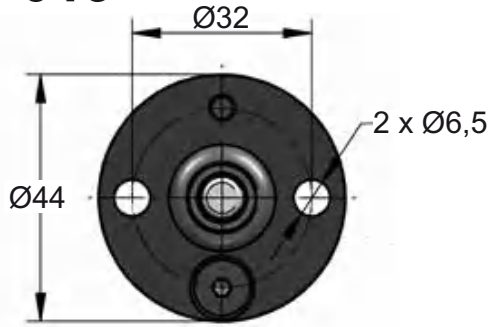

## A19-019

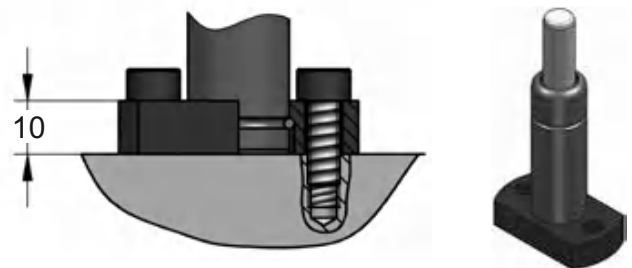
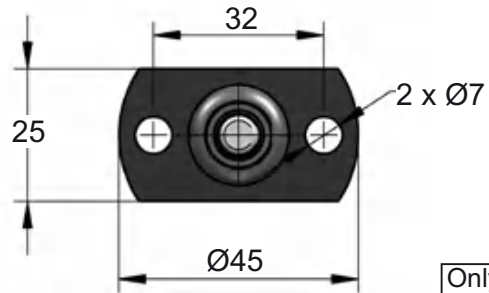

Only to be used for strokes 7-25 mm

## A44-019

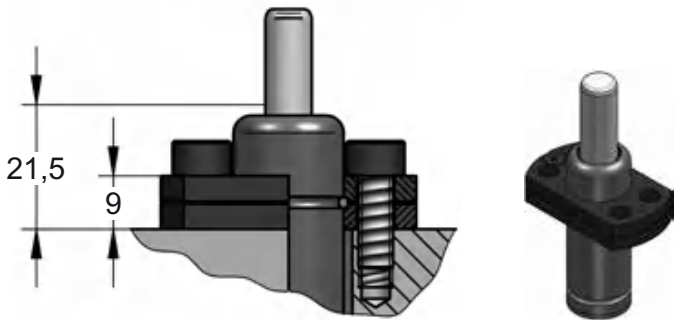
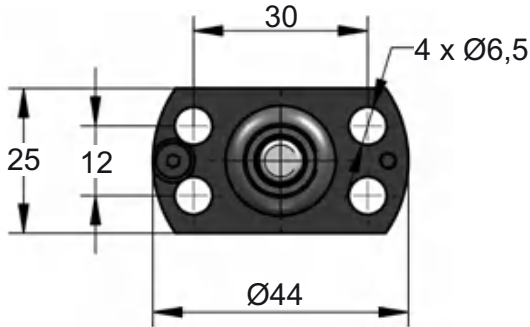

## A59-019

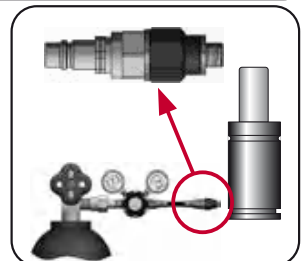
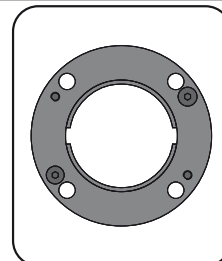
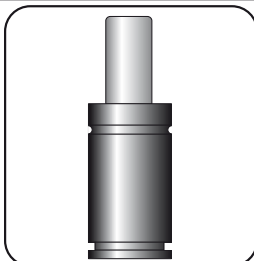
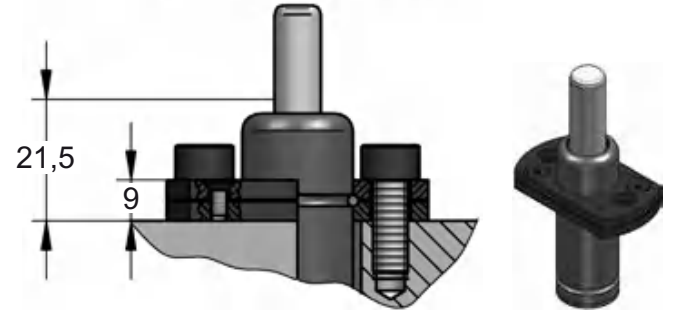
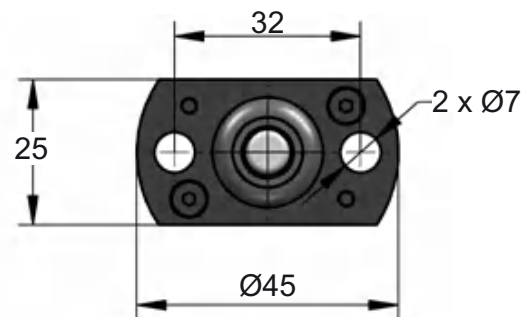

CODE	CW 170 050 V1	<b>X</b>	A14-019	06 CG 2-Q
ENG ORDER	GAS SPRING	REPAIR KIT	FLANGE	CHARGING ADAPTER
DEU BESTELLUNG	GASDRUCKFEDER	ERSATZTEILSATZ	FLANSCH	LADEADAPTER
FRA COMMANDE	RESSORT À GAZ	KIT DE RÉPARATION	BRIDE	RACCORD DE CHARGE
ITA ORDINE	CILINDRO AD AZOTO	KIT DI MANUTENZIONE	FLANGE	ADATTATORE DI CARICO
ESP PEDIDO	RESORTE DE GAS	KIT DE REPARACION	BRIDA	ADAPTADOR DE CARGA
POR PEDIDO	CILINDRO DE GÁS	KIT DE MANUTENÇÃO	FLANGE	ADAPTADOR DE CARGA

# CW 320 V1

Compact Height

VW 39D 997		
------------	--	--

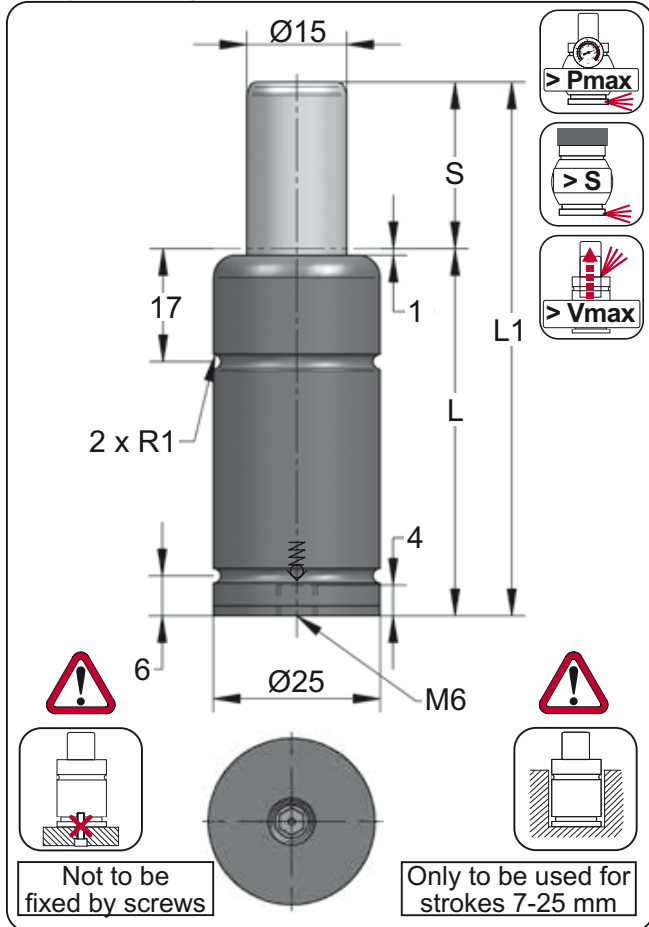

Not to be fixed by screws

Only to be used for strokes 7-25 mm

ORDER	S (mm)	L1 ±0.25 (mm)	L (mm)	Kg.
CW 320 007 V1	7	44	37	0.11
CW 320 010 V1	10	50	40	0.11
CW 320 012 V1	12	54	42	0.12
CW 320 015 V1	15	60	45	0.13
CW 320 019 V1	19	68	49	0.13
CW 320 025 V1	25	80	55	0.15
CW 320 032 V1	32	94	62	0.16
CW 320 038 V1	38	106	68	0.18
CW 320 050 V1	50	130	80	0.21
CW 320 063 V1	63	156	93	0.23
CW 320 075 V1	75	185	110	0.26
CW 320 080 V1	80	195	115	0.27
CW 320 100 V1	100	235	135	0.32
CW 320 125 V1	125	285	160	0.38



CODE	Image	Pressure		Force	
		bar	psi	daN	daN
CW 320 050 V1		180	2610	320	585
-----		-----	-----	-----	-----

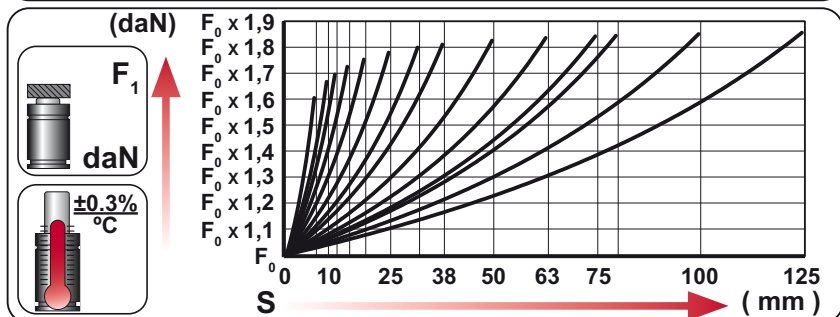
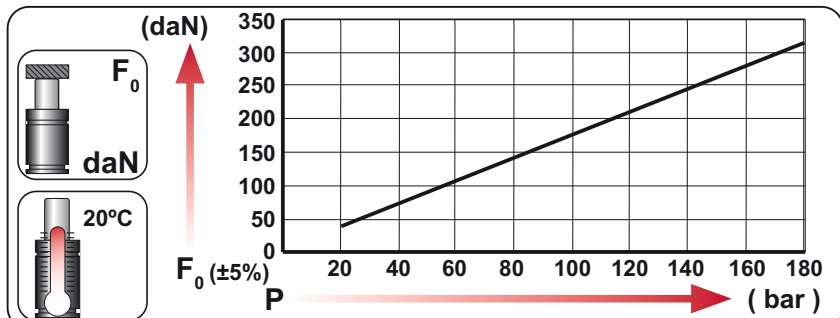

**EQUIPPED WITH VDI - SAFETY**

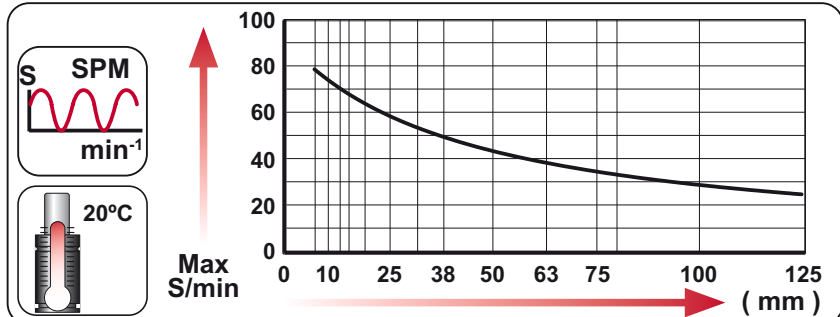

Language	Order Code	Force F0 (daN)	Stroke S (mm)
ENG	ORDER		
DEU	BESTELLUNG	320	50
FRA	COMMANDE		
ITA	ORDINE		
ESP	PEDIDO		
POR	PEDIDO		

	Smax < 90%	Vmax 1,6 m/s	Pmin (20°C)	Pmax (20°C)	Tmin	Tmax	
--	------------	--------------	-------------	-------------	------	------	--

N <sub>2</sub>	Smax < 90%	Vmax 1,6 m/s	bar psi	bar psi	°C °F	°C °F	
			20 290	180 2610	0 32	80 176	





# CW 320 V1 MOUNTS

Compact Height

## A19-025

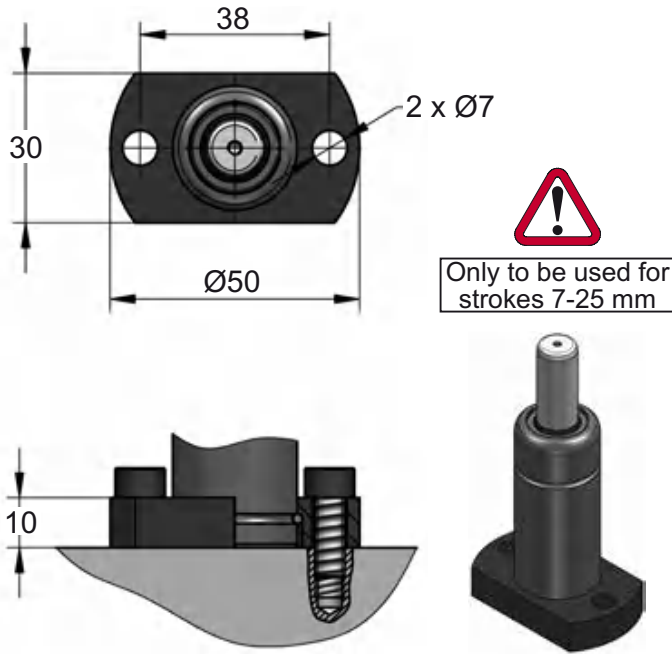

## A44-025

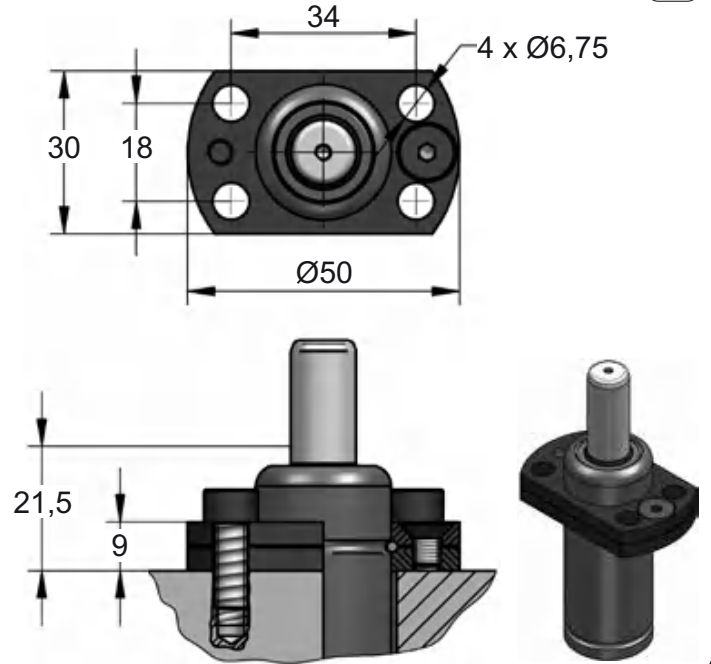

## A49-025

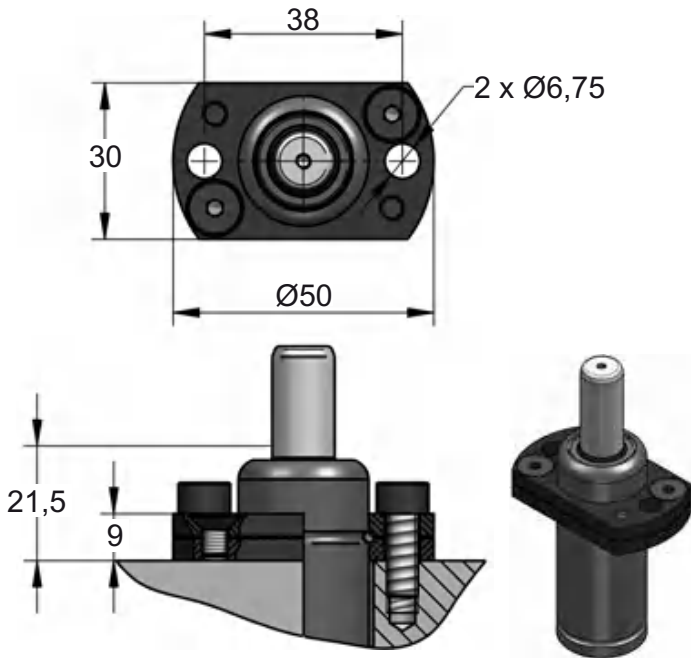

## D02-025

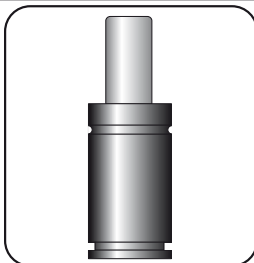
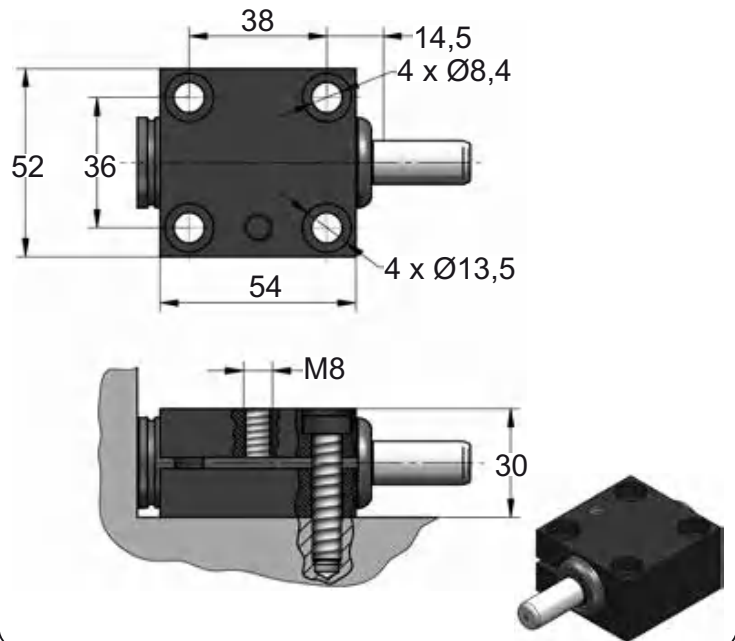

SEAL KIT S-XXXXXXX



CARTRIDGE KIT C-XXXXXXX

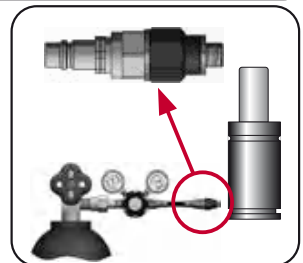
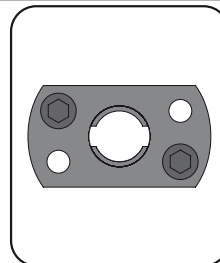

CODE	CW 320 050 V1	<b>X</b>	A19-025	06 CG 2-Q
ENG ORDER	GAS SPRING		FLANGE	CHARGING ADAPTER
DEU BESTELLUNG	GASDRUCKFEDER		FLANSCH	LADEADAPTER
FRA COMMANDE	RESSORT À GAZ		BRIDE	RACCORD DE CHARGE
ITA ORDINE	CILINDRO AD AZOTO		FLANGE	ADATTATORE DI CARICO
ESP PEDIDO	RESORTE DE GAS		BRIDA	ADAPTADOR DE CARGA
POR PEDIDO	CILINDRO DE GÁS		FLANGE	ADAPTADOR DE CARGA

# CW 350 V1

Compact Height

BMW B2 4005	FORD W-DX35-6204
MB B8 3180 220 000 004	GM 90.25.08
VW 39D 997	

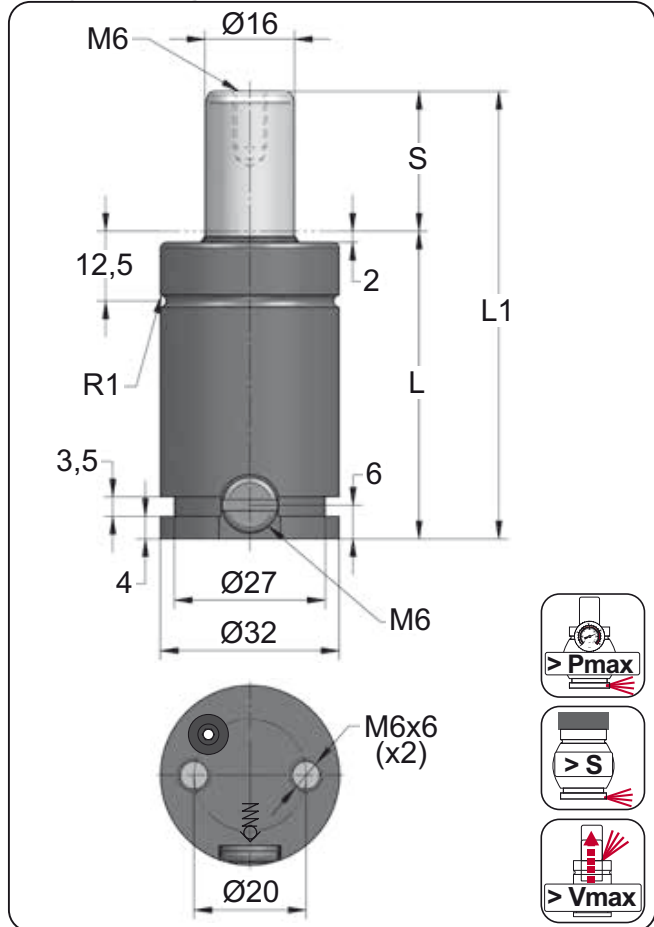

ORDER	S (mm)	L1 ±0.25 (mm)	L (mm)	Kg.
CW 350 010 V1	10	50	40	0.18
CW 350 013 V1	13	56	43	0.19
CW 350 016 V1	16	62	46	0.20
CW 350 019 V1	19	68	49	0.21
CW 350 025 V1	25	80	55	0.23
CW 350 032 V1	32	94	62	0.25
CW 350 038 V1	38	106	68	0.28
CW 350 050 V1	50	130	80	0.32
CW 350 063 V1	63	156	93	0.36
CW 350 075 V1	75	180	105	0.40
CW 350 080 V1	80	190	110	0.42
CW 350 100 V1	100	230	130	0.49
CW 350 125 V1	125	280	155	0.57



CODE	Image	Pressure		Force	
		bar	psi	daN	daN
CW 350 050 V1		180	2610	360	550
CW-H 350 050 V1		0	0	---	---

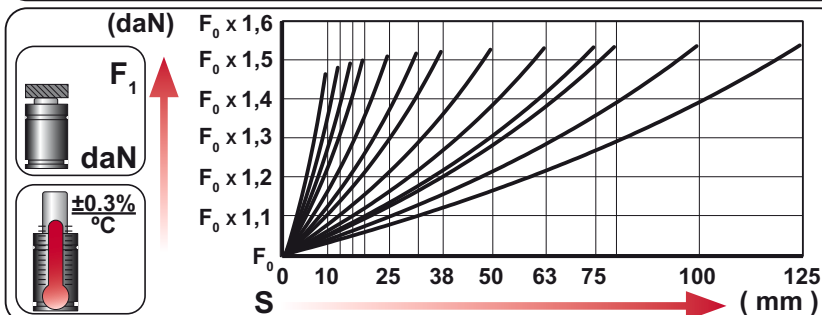
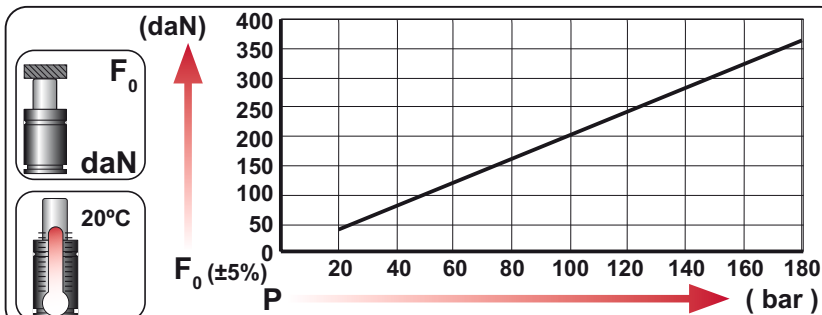

**EQUIPPED WITH VDI - SAFETY**

Language	Order Term	Force F0 (daN)	Stroke S (mm)
ENG	ORDER		
DEU	BESTELLUNG		
FRA	COMMANDE		
ITA	ORDINE		
ESP	PEDIDO		
POR	PEDIDO		

**CW 350 050 V1**      **350**      **50**

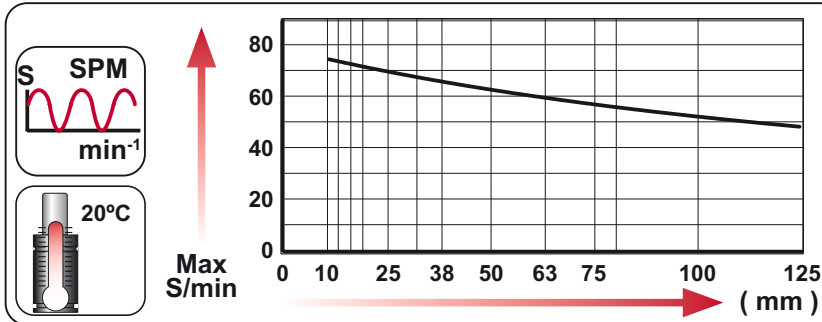

--	--	--	--	--	--

N <sub>2</sub>	Smax < 90%	Vmax 1,6 m/s	bar psi	bar psi	°C °F	°C °F	600 CP-
			20 290	180 2610	0 32	80 176	



# CW 350 V1 MOUNTS

Compact Height

### A14-032

ISO E24.54.815.G  
EM24.54.700/F

### A34-032

VDI

### C20-032

VDI E24.54.815.G  
EM24.54.700/F

### D02-032

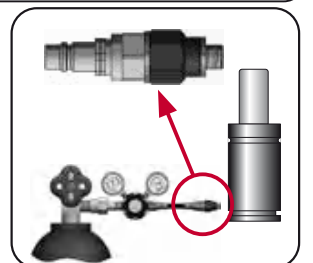
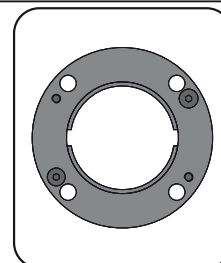
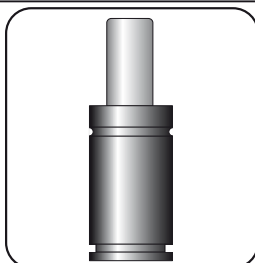

CODE	CW 350 050 V1	KIT S-XXXXXXX KIT C-XXXXXXX	A14-032	06 CG 2-Q
ENG	ORDER	GAS SPRING	REPAIR KIT	CHARGING ADAPTER
DEU	BESTELLUNG	GASDRUCKFEDER	ERSATZTEILSATZ	LADEADAPTER
FRA	COMMANDE	RESSORT À GAZ	KIT DE RÉPARATION	RACCORD DE CHARGE
ITA	ORDINE	CILINDRO AD AZOTO	KIT DI MANUTENZIONE	ADATTATORE DI CARICO
ESP	PEDIDO	RESORTE DE GAS	KIT DE REPARACION	ADAPTADOR DE CARGA
POR	PEDIDO	CILINDRO DE GÁS	KIT DE MANUTENÇÃO	ADAPTADOR DE CARGA

# CW 500 V1

Compact Height

BMW B2 4005	FORD W-DX35-6204	PSA E24.54.815.G
MB B8 3180 220 000 004	GM 90.25.08	
VW 39D 997		

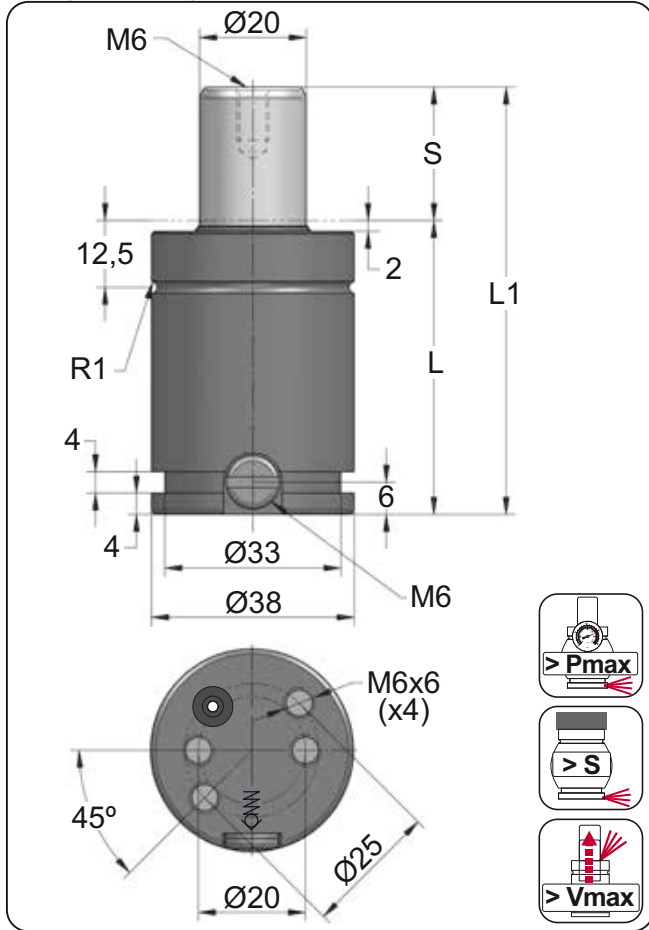

ORDER	S (mm)	L1 ±0.25 (mm)	L (mm)	Kg.
CW 500 010 V1	10	50	40	0.24
CW 500 013 V1	13	56	43	0.26
CW 500 016 V1	16	62	46	0.27
CW 500 019 V1	19	68	49	0.28
CW 500 025 V1	25	80	55	0.31
CW 500 032 V1	32	94	62	0.33
CW 500 038 V1	38	106	68	0.36
CW 500 050 V1	50	130	80	0.41
CW 500 063 V1	63	156	93	0.46
CW 500 075 V1	75	180	105	0.51
CW 500 080 V1	80	190	110	0.53
CW 500 100 V1	100	230	130	0.61
CW 500 125 V1	125	280	155	0.71



CODE	Image	Pressure		Force	
		bar	psi	daN	daN
CW 500 050 V1		150	2175	470	710
CW-H 500 050 V1		0	0	---	---

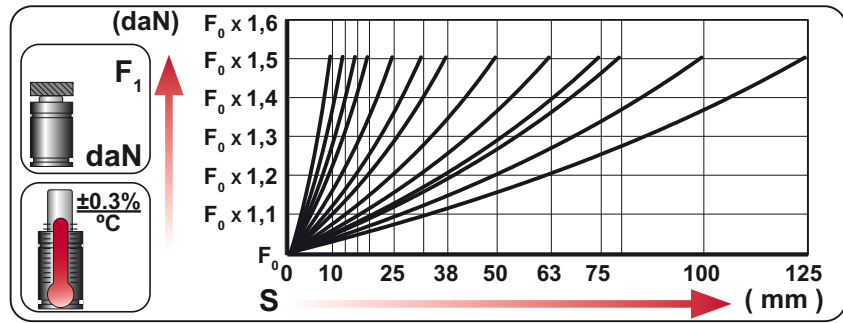
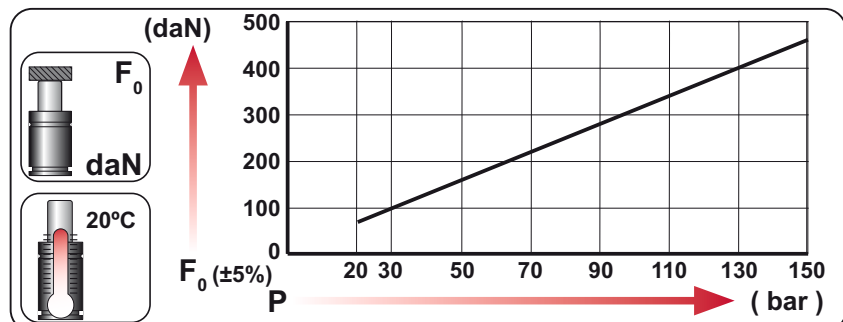

**EQUIPPED WITH VDI - SAFETY**

Language	Order	Force (daN)	Stroke (mm)
ENG	ORDER	F <sub>0</sub>	S
DEU	BESTELLUNG	daN	mm
FRA	COMMANDE		
ITA	ORDINE		
ESP	PEDIDO		
POR	PEDIDO		
<b>CW 500 050 V1</b>		<b>500</b>	<b>50</b>

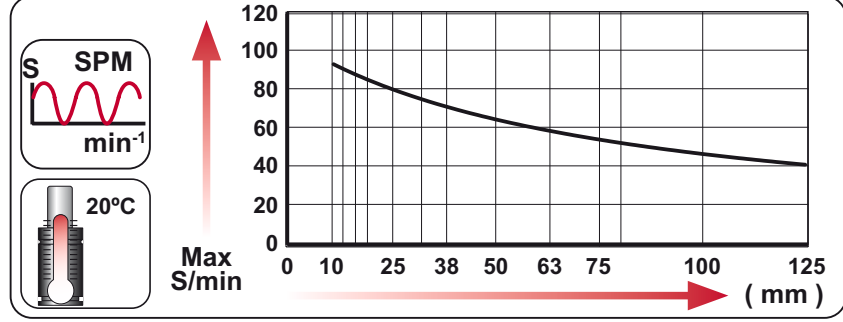

N <sub>2</sub>	S <sub>max</sub> < 90%	V <sub>max</sub> 1,6 m/s	P <sub>min</sub> (20°C)	P <sub>max</sub> (20°C)	T <sub>min</sub>	T <sub>max</sub>	600 CP-

N <sub>2</sub>	S <sub>max</sub> < 90%	V <sub>max</sub> 1,6 m/s	bar psi	bar psi	°C °F	°C °F	600 CP-
			20 290	150 2175	0 32	80 176	





# CW 500 V1 MOUNTS

Compact Height

### A14-038

ISO NAMM 32 CNOBO E24.54.815.G EM24.54.700/F

### A34-038

ISO VDI

### C20-038

ISO NAMM 32 VDI CNOBO E24.54.815.G EM24.54.700/F

### D02-038

CNOBO E24.54.815.G

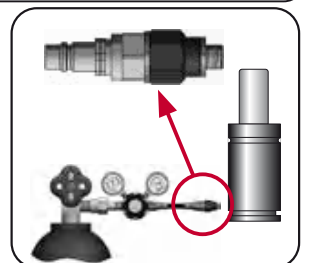
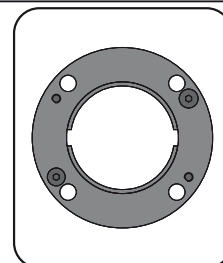
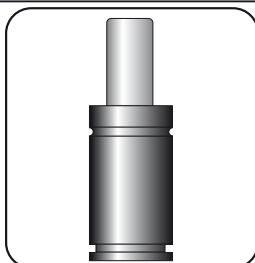
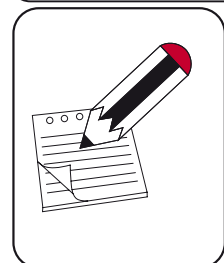

CODE	CW 500 050 V1	KIT S-XXXXXXX KIT C-XXXXXXX	A14-038	06 CG 2-Q
ENG	ORDER	GAS SPRING	REPAIR KIT	CHARGING ADAPTER
DEU	BESTELLUNG	GASDRUCKFEDER	ERSATZTEILSATZ	LADEADAPTER
FRA	COMMANDE	RESSORT À GAZ	KIT DE RÉPARATION	RACCORD DE CHARGE
ITA	ORDINE	CILINDRO AD AZOTO	KIT DI MANUTENZIONE	ADATTATORE DI CARICO
ESP	PEDIDO	RESORTE DE GAS	KIT DE REPARACION	ADAPTADOR DE CARGA
POR	PEDIDO	CILINDRO DE GÁS	KIT DE MANUTENÇÃO	ADAPTADOR DE CARGA

# CW 750 V1

Compact Height

BMW B2 4005	FORD W-DX35-6204	PSA E24.54.815.G
MB B8 3180 220 000 004	GM 90.25.08	
VW 39D 997		

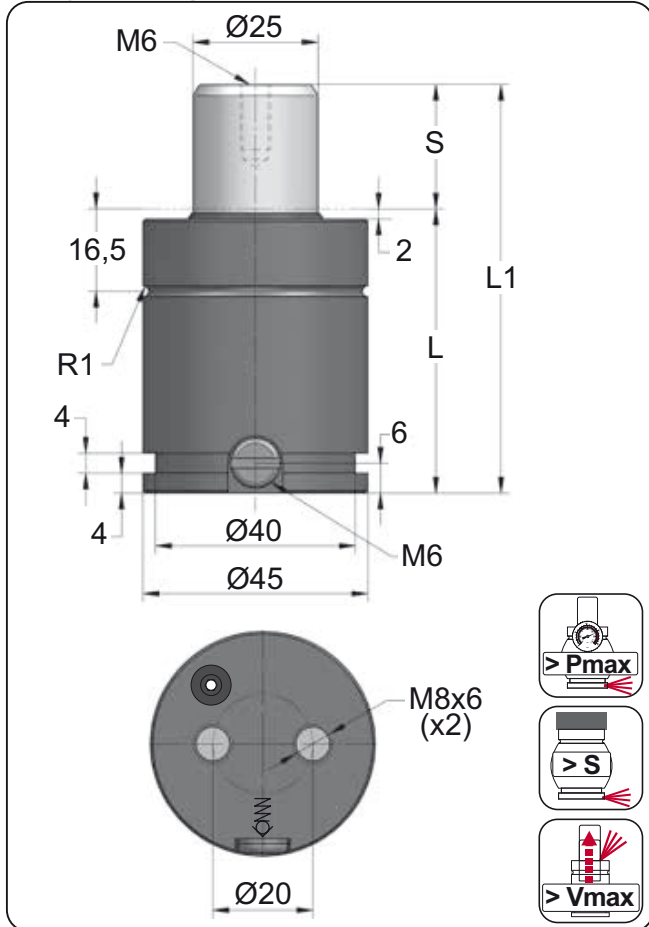

ORDER	S (mm)	L1 ±0.25 (mm)	L (mm)	Kg.
CW 750 010 V1	10	52	42	0.38
CW 750 013 V1	13	58	45	0.40
CW 750 016 V1	16	64	48	0.42
CW 750 019 V1	19	70	51	0.44
CW 750 025 V1	25	82	57	0.47
CW 750 032 V1	32	96	64	0.52
CW 750 038 V1	38	108	70	0.55
CW 750 050 V1	50	132	82	0.63
CW 750 063 V1	63	158	95	0.71
CW 750 075 V1	75	182	107	0.78
CW 750 080 V1	80	192	112	0.82
CW 750 100 V1	100	232	132	0.94
CW 750 125 V1	125	282	157	1.10



CODE	Image	Pressure		Force	
		bar	psi	daN	daN
CW 750 050 V1		150	2175	740	1175
CW-H 750 050 V1		0	0	---	---

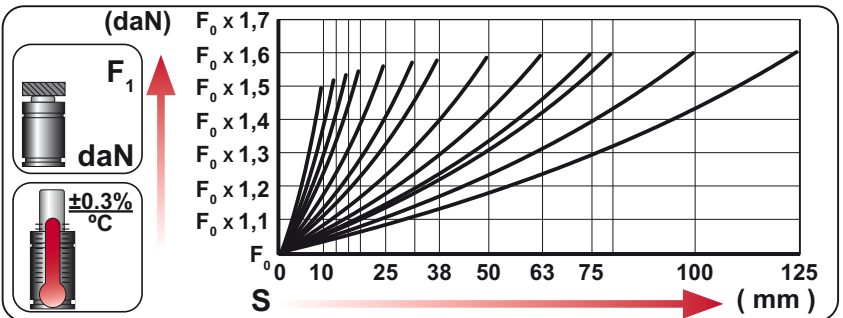
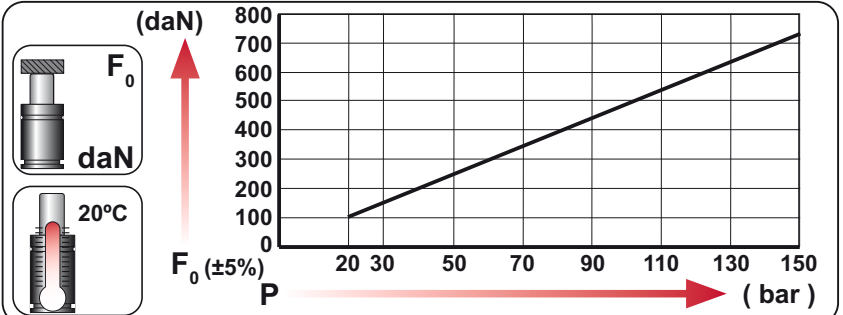

**EQUIPPED WITH VDI - SAFETY**

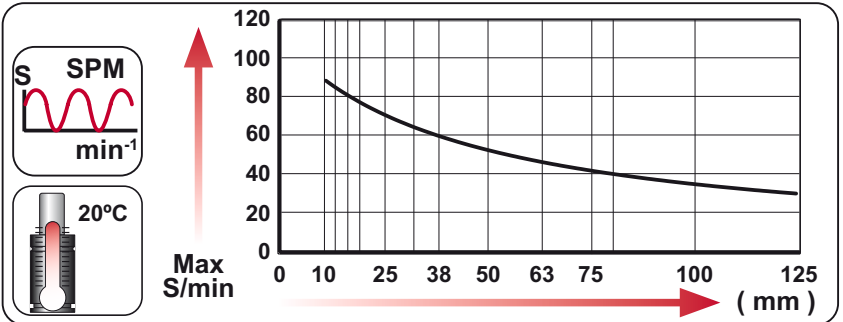

Language	ORDER	F0 daN	S mm
ENG	ORDER	750	50
DEU	BESTELLUNG		
FRA	COMMANDE		
ITA	ORDINE		
ESP	PEDIDO		
POR	PEDIDO		

--	--	--	--	--	--

N <sub>2</sub>	Smax < 90%	Vmax 1,6 m/s	bar psi	bar psi	°C °F	°C °F	600 CP-
			20 290	150 2175	0 32	80 176	



# CW 750 V1

Compact Height

s mm Ø mm L1 mm		<p>50</p> <p>Ø45</p> <p>L1=132 L1=147</p>		<p>50</p> <p>Ø45</p> <p>L1=138 L1=150 L1=150</p>	<p>50</p> <p>Ø45</p> <p>L1=160 L1=185</p>	<p>50</p> <p>Ø45</p> <p>L1=185</p>	<p>50</p> <p>Ø45</p> <p>L1=160</p>	
MODEL	X	CW 750 KZ 750	X	CT 700 CK 750 FD 500	CM 600 CD 700	AG 500	CPH 1250	X
SERIES	MINI 	COMPACT HEIGHT 	THREADED 	LOW PROFILE 	HEAVY DUTY 	ISO 	HEAVY LOAD 	POWER COMPACT STROKE 

<h2>CW</h2> <p>KRM6</p> <p>BK</p>	<h2>CWC</h2> <p>DRM8</p> <p>9RM8</p> <p>7RM8</p> <p>SKK</p> <p>TNRR</p> <p>MCRR</p> <p>TFRR</p> <p>SGS</p>
-----------------------------------	--

		<p>SEAL KIT S-XXXXXXX</p> <p>CARTRIDGE KIT C-XXXXXXX</p>		
--	--	--	--	--

CODE	CW 750 050 V1	KIT S-XXXXXXX KIT C-XXXXXXX	A14-045	06 CG 2-Q
ENG ORDER	GAS SPRING	REPAIR KIT	FLANGE	CHARGING ADAPTER
DEU BESTELLUNG	GASDRUCKFEDER	ERSATZTEILSATZ	FLANSCHEN	LADEADAPTER
FRA COMMANDE	RESSORT À GAZ	KIT DE RÉPARATION	BRIDE	RACCORD DE CHARGE
ITA ORDINE	CILINDRO AD AZOTO	KIT DI MANUTENZIONE	FLANGE	ADATTATORE DI CARICO
ESP PEDIDO	RESORTE DE GAS	KIT DE REPARACION	BRIDA	ADAPTADOR DE CARGA
POR PEDIDO	CILINDRO DE GÁS	KIT DE MANUTENÇÃO	FLANGE	ADAPTADOR DE CARGA

# CWC 750 V2

Compact Height

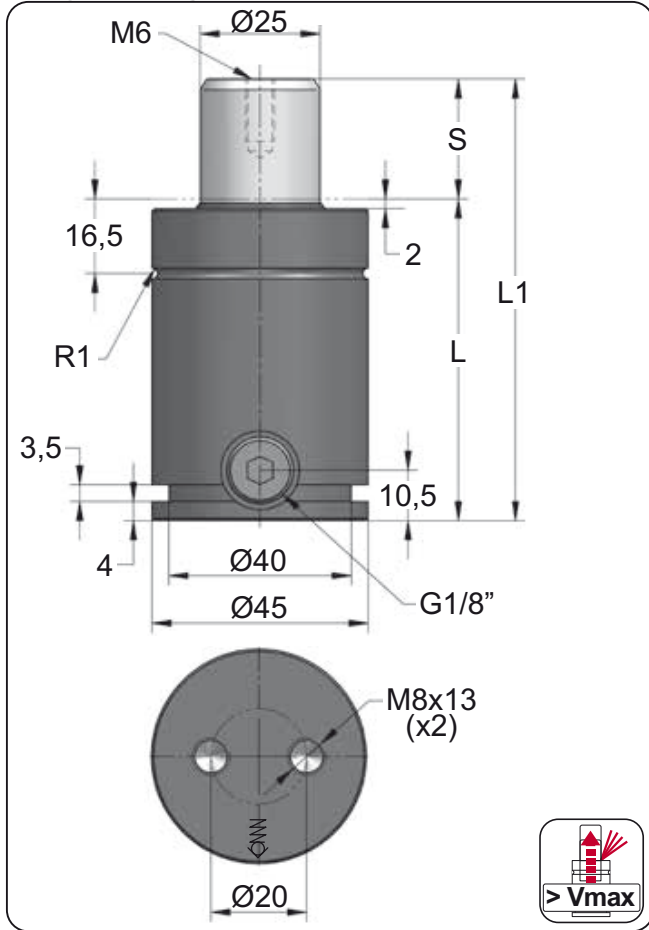

ORDER	S (mm)	L1 ±0,25 (mm)	L (mm)	Kg.
CWC 750 010 V2	10	62	52	0.49
CWC 750 013 V2	13	68	55	0.50
CWC 750 016 V2	16	74	58	0.52
CWC 750 019 V2	19	80	61	0.54
CWC 750 025 V2	25	92	67	0.58
CWC 750 032 V2	32	106	74	0.62
CWC 750 038 V2	38	118	80	0.66
CWC 750 050 V2	50	142	92	0.74
CWC 750 063 V2	63	168	105	0.82
CWC 750 075 V2	75	192	117	0.89
CWC 750 080 V2	80	202	122	0.92
CWC 750 100 V2	100	242	142	1.05
CWC 750 125 V2	125	292	167	1.20

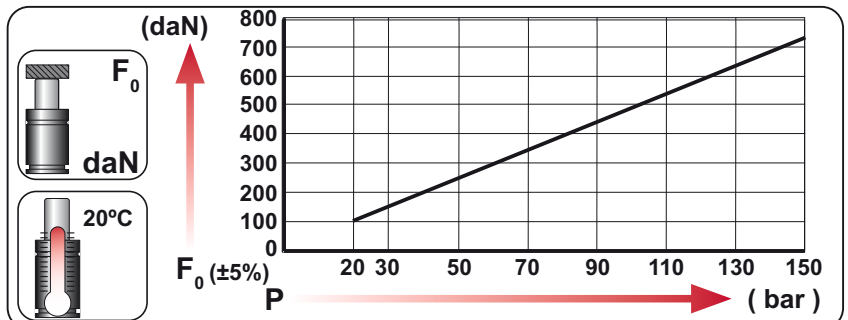

CODE	Image	Pressure		Force	
		bar	psi	daN	daN
CWC 750 050 V2		150	2175	740	1175
CWC-H 750 050 V2		0	0	---	---

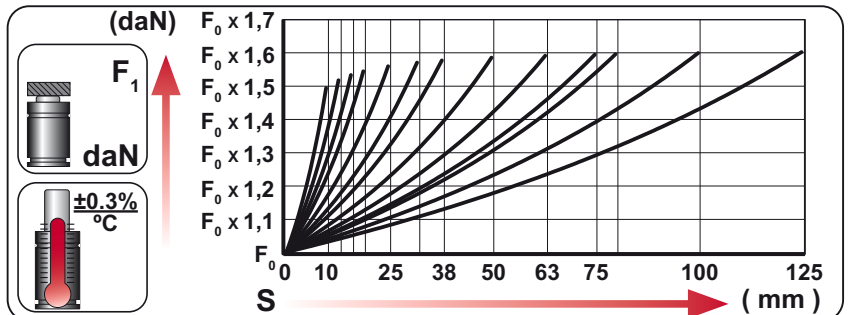

Language	Order Code	Force F0 (daN)	Stroke S (mm)
ENG	ORDER	750	50
DEU	BESTELLUNG	750	50
FRA	COMMANDE	750	50
ITA	ORDINE	750	50
ESP	PEDIDO	750	50
POR	PEDIDO	750	50

**CWC 750 050 V2**

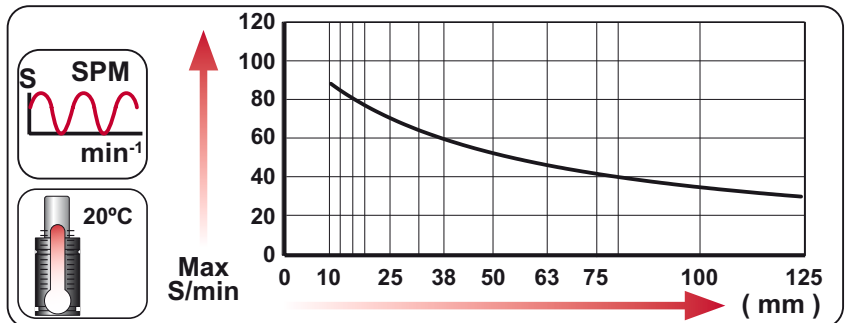

			bar psi	bar psi	°C °F	°C °F	600 CP-
N <sub>2</sub>	Smax < 90%	Vmax 1,6 m/s	20 290	150 2175	0 32	80 176	





# CWC 750 V2

Compact Height

	MODEL	CWC 750	CW 750

<p><b>CW</b></p> <p><b>KRM6</b> </p> <p><b>BK</b> </p>	<p><b>CWC</b></p> <p><b>DRM8</b> </p> <p><b>9RM8</b> </p> <p><b>7RM8</b> </p> <p><b>SKK</b> </p> <p><b>TNRR</b> </p> <p><b>MCRR</b> </p> <p><b>TFRR</b> </p> <p><b>SGS</b> </p>
--	---

		<p><b>SEAL KIT S-XXXXXXX</b></p> <p><b>CARTRIDGE KIT C-XXXXXXX</b></p>		
--	--	--	--	--

CODE	CWC 750 050 V2	KIT S-XXXXXXX KIT C-XXXXXXX	A14-045	18 CG 1-Q
ENG	ORDER	GAS SPRING	REPAIR KIT	FLANGE
DEU	BESTELLUNG	GASDRUCKFEDER	ERSATZTEILSATZ	FLANSCHEN
FRA	COMMANDE	RESSORT À GAZ	KIT DE RÉPARATION	BRIDE
ITA	ORDINE	CILINDRO AD AZOTO	KIT DI MANUTENZIONE	FLANGE
ESP	PEDIDO	RESORTE DE GAS	KIT DE REPARACION	BRIDA
POR	PEDIDO	CILINDRO DE GÁS	KIT DE MANUTENÇÃO	FLANGE
				CHARGING ADAPTER
				LADEADAPTER
				RACCORD DE CHARGE
				ADATTATORE DI CARICO
				ADAPTADOR DE CARGA
				ADAPTADOR DE CARGA

# CW 750 V1/CWC 750 V2 MOUNTS



Compact Height

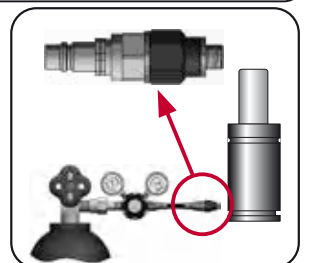
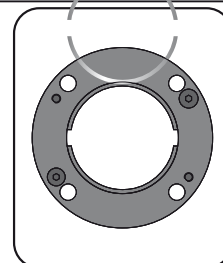
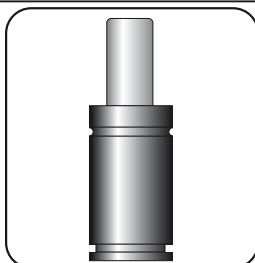
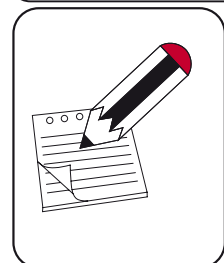
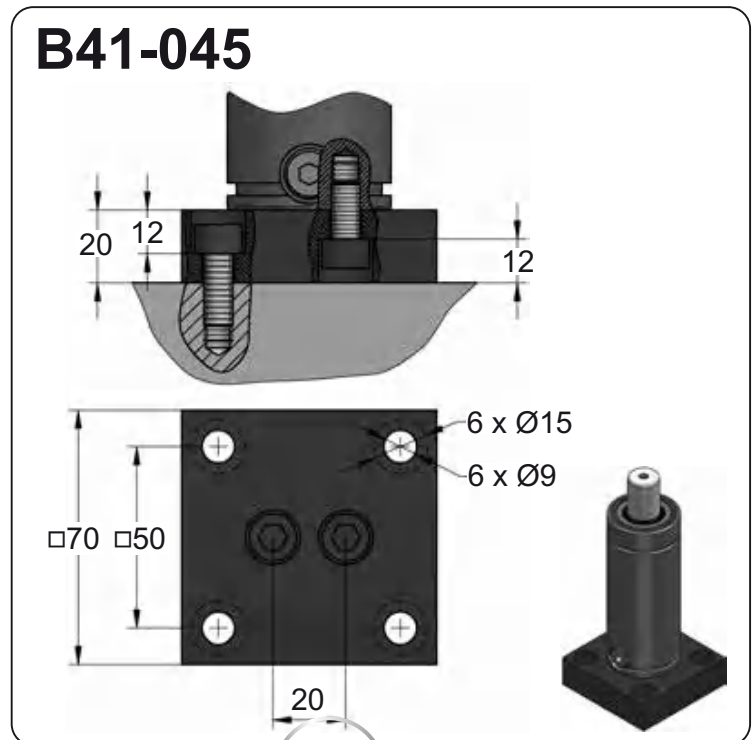
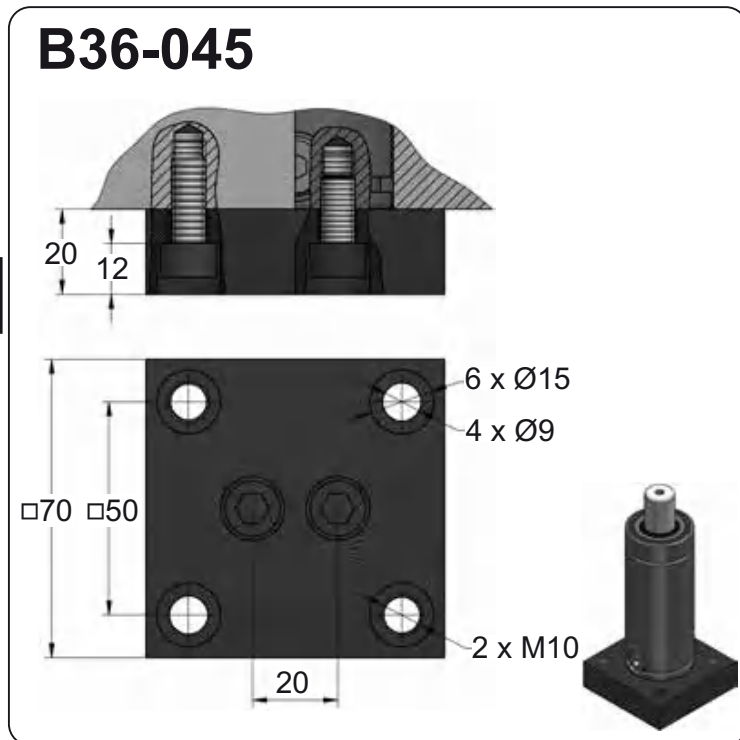
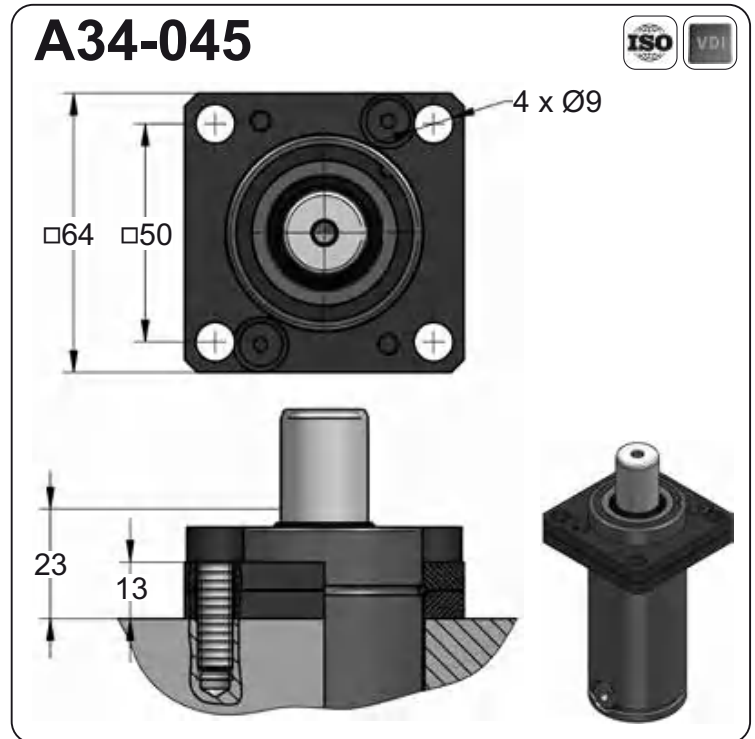

CODE	CWC 750 050 V2	KIT S-XXXXXXX KIT C-XXXXXXX	A14-045	18 CG 1-Q
ENG	ORDER	GAS SPRING	REPAIR KIT	CHARGING ADAPTER
DEU	BESTELLUNG	GASDRUCKFEDER	ERSATZTEILSATZ	LADEADAPTER
FRA	COMMANDE	RESSORT À GAZ	KIT DE RÉPARATION	RACCORD DE CHARGE
ITA	ORDINE	CILINDRO AD AZOTO	KIT DI MANUTENZIONE	ADATTATORE DI CARICO
ESP	PEDIDO	RESORTE DE GAS	KIT DE REPARACION	ADAPTADOR DE CARGA
POR	PEDIDO	CILINDRO DE GÁS	KIT DE MANUTENÇÃO	ADAPTADOR DE CARGA



# CW 750 V1/CWC 750 V2 MOUNTS

Compact Height

## C05-045

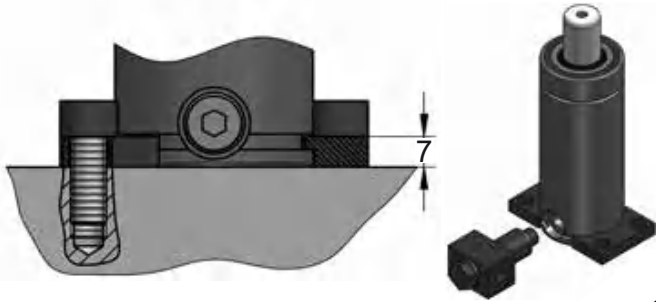
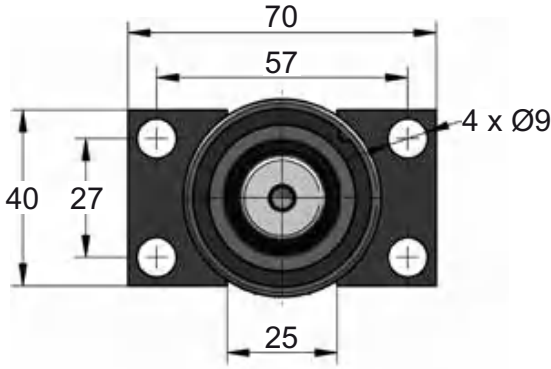

## C20-045

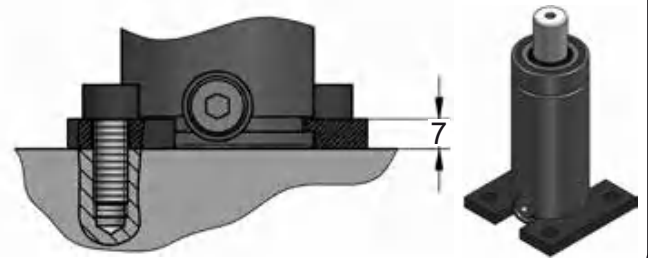
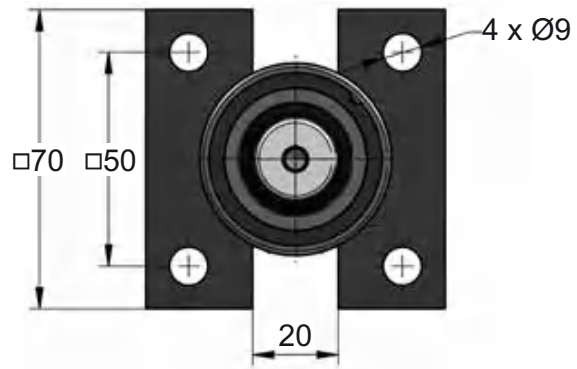

## D02-045

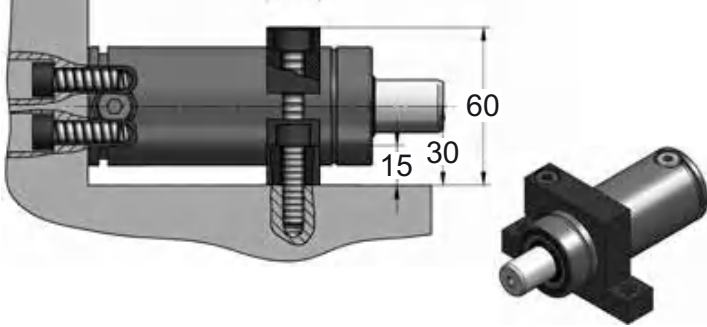
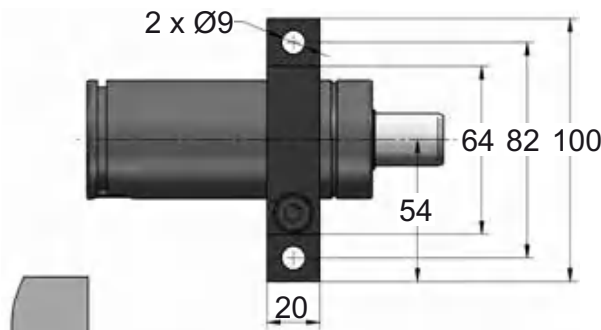

## D67-045

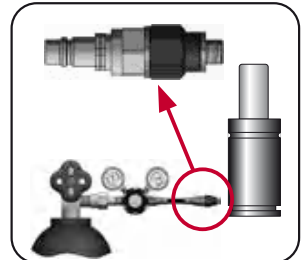
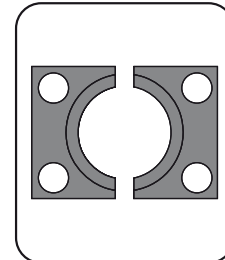
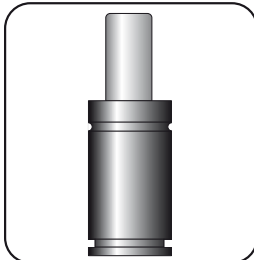
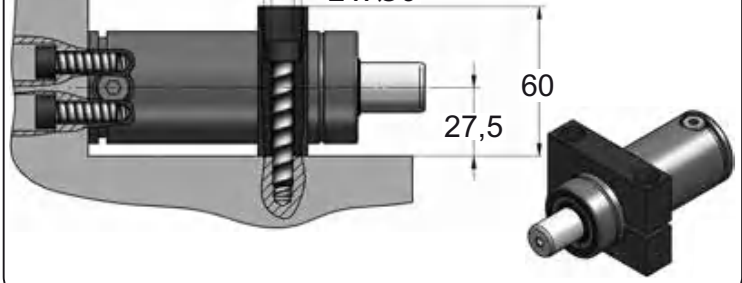
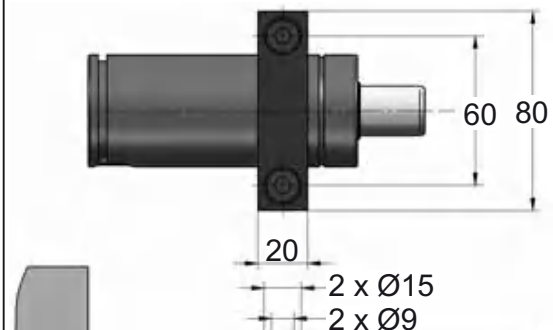

CODE	CWC 750 050 V2	KIT S-XXXXXXX KIT C-XXXXXXX	C05-045	18 CG 1-Q
ENG	ORDER	GAS SPRING	REPAIR KIT	CHARGING ADAPTER
DEU	BESTELLUNG	GASDRUCKFEDER	ERSATZTEILSATZ	LADEADAPTER
FRA	COMMANDE	RESSORT À GAZ	KIT DE RÉPARATION	RACCORD DE CHARGE
ITA	ORDINE	CILINDRO AD AZOTO	KIT DI MANUTENZIONE	ADATTATORE DI CARICO
ESP	PEDIDO	RESORTE DE GAS	KIT DE REPARACION	ADAPTADOR DE CARGA
POR	PEDIDO	CILINDRO DE GÁS	KIT DE MANUTENÇÃO	ADAPTADOR DE CARGA

# CW 1000 V2

Compact Height

BMW B2 4005	FORD W-DX35-6204	PSA E24.54.815.G
MB B8 3180 220 000 004	GM 90.25.08	
VW 39D 997		

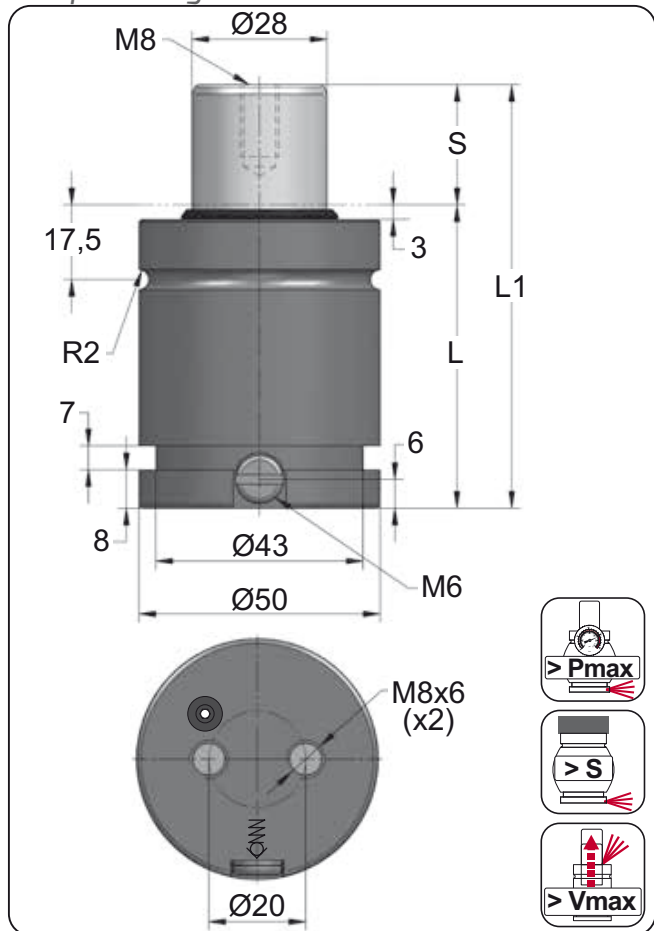

ORDER	S (mm)	L1 ±0.25 (mm)	L (mm)	Kg.
CW 1000 010 V2	10	58	48	0.53
CW 1000 013 V2	13	64	51	0.56
CW 1000 016 V2	16	70	54	0.58
CW 1000 019 V2	19	76	57	0.61
CW 1000 025 V2	25	88	63	0.66
CW 1000 032 V2	32	102	70	0.72
CW 1000 038 V2	38	114	76	0.77
CW 1000 050 V2	50	138	88	0.87
CW 1000 063 V2	63	164	101	0.98
CW 1000 075 V2	75	188	113	1.08
CW 1000 080 V2	80	198	118	1.12
CW 1000 100 V2	100	238	138	1.29
CW 1000 125 V2	125	288	163	1.50

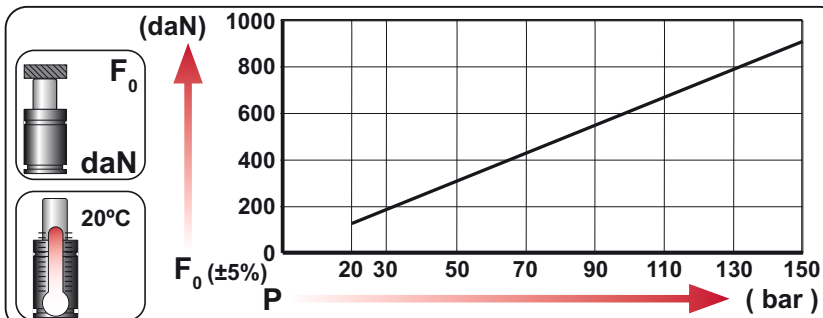

CODE	Image	Pressure		Force	
		bar	psi	daN	daN
CW 1000 050 V2		150	2175	920	1505
CW-H 1000 050 V2		0	0	---	---

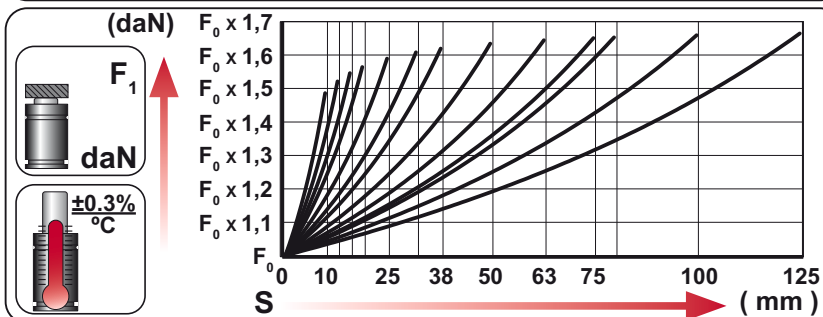

**EQUIPPED WITH VDI - SAFETY**

ENG ORDER	DEU BESTELLUNG	FRA COMMANDE	ITA ORDINE	ESP PEDIDO	POR PEDIDO	Force	
						daN	mm
CW 1000 050 V2						1000	50

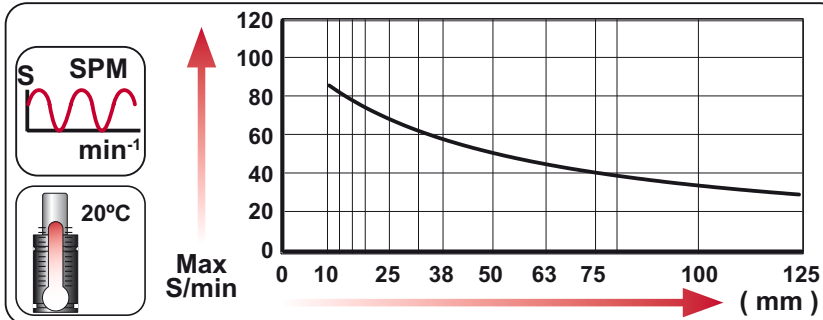

--	--	--	--	--	--	--	--

N <sub>2</sub>	Smax < 90%	Vmax 1,6 m/s	bar psi	bar psi	°C °F	°C °F	600 CP-
			20 290	150 2175	0 32	80 176	





# CW 1000 V2

Compact Height

  		50	50	50	50	50	50	50
		<b>Ø50</b>	<b>Ø50</b>	<b>Ø50</b>	<b>Ø50</b>	<b>Ø50</b>	<b>Ø50</b>	<b>Ø50</b>
		<b>L1=138</b> <b>L1=152</b> <b>L1=152</b>		<b>L1=138</b> <b>L1=150</b> <b>L1=150</b>	<b>L1=170</b> <b>L1=185</b> <b>L1=195</b>	<b>L1=195</b>	<b>L1=165</b> <b>L1=175</b>	<b>L1=220</b>
<b>MODEL</b>	<b>X</b>	<b>CW 1000</b> <b>KZ 1000</b> <b>KT 1000</b>	<b>X</b>	<b>CT 750</b> <b>CK 1000</b> <b>FD 750</b>	<b>GN 750</b> <b>CM 1000</b> <b>CD 1000</b>	<b>AG 750</b>	<b>CPH 1700</b> <b>CP 2000</b>	<b>CS 1800</b>
<b>SERIES</b>	<b>MINI</b>	<b>COMPACT HEIGHT</b>	<b>THREADED</b>	<b>LOW PROFILE</b>	<b>HEAVY DUTY</b>	<b>ISO</b>	<b>HEAVY LOAD</b>	<b>POWER COMPACT STROKE</b>

### CW

**KRM6**

**BK**

### CWC

**DRM8**

**TNRR**

**9RM8**

**MCRR**

**7RM8**

**TFRR**

**SKK**

**SGS**

**SEAL KIT S-XXXXXXX**

**CARTRIDGE KIT C-XXXXXXX**

<b>CODE</b>	<b>CW 1000 050 V2</b>	<b>KIT S-XXXXXXX</b> <b>KIT C-XXXXXXX</b>	<b>A14-050</b>	<b>06 CG 2-Q</b>
<b>ENG</b>	<b>ORDER</b>	<b>GAS SPRING</b>	<b>REPAIR KIT</b>	<b>FLANGE</b>
<b>DEU</b>	<b>BESTELLUNG</b>	<b>GASDRUCKFEDER</b>	<b>ERSATZTEILSATZ</b>	<b>FLANSCH</b>
<b>FRA</b>	<b>COMMANDE</b>	<b>RESSORT À GAZ</b>	<b>KIT DE RÉPARATION</b>	<b>BRIDE</b>
<b>ITA</b>	<b>ORDINE</b>	<b>CILINDRO AD AZOTO</b>	<b>KIT DI MANUTENZIONE</b>	<b>FLANGE</b>
<b>ESP</b>	<b>PEDIDO</b>	<b>RESORTE DE GAS</b>	<b>KIT DE REPARACION</b>	<b>BRIDA</b>
<b>POR</b>	<b>PEDIDO</b>	<b>CILINDRO DE GÁS</b>	<b>KIT DE MANUTENÇÃO</b>	<b>FLANGE</b>
				<b>CHARGING ADAPTER</b>
				<b>LADEADAPTER</b>
				<b>RACCORD DE CHARGE</b>
				<b>ADATTATORE DI CARICO</b>
				<b>ADAPTADOR DE CARGA</b>
				<b>ADAPTADOR DE CARGA</b>

# CWC 1000 V2

Compact Height

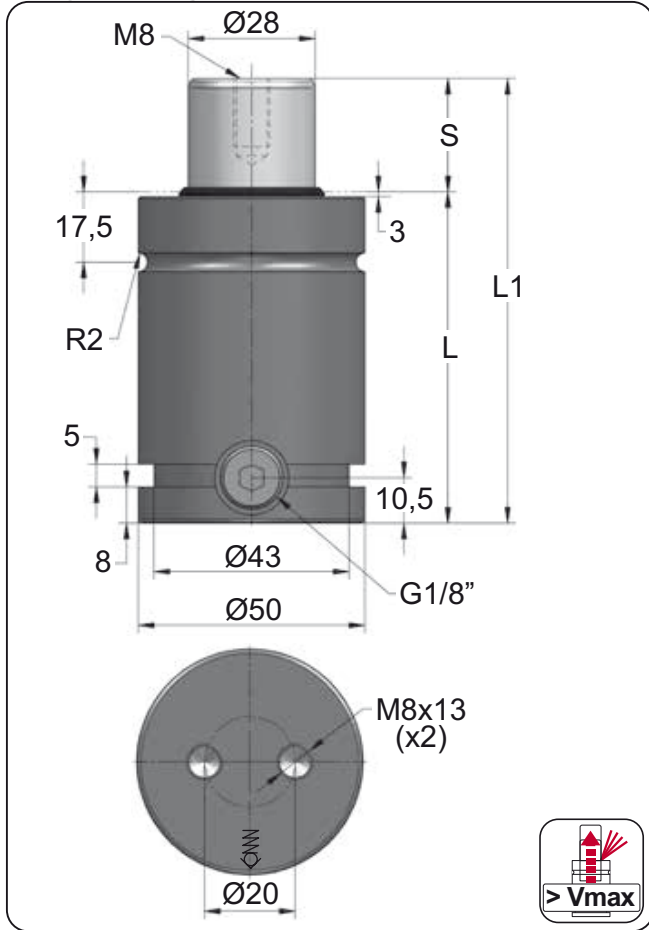

ORDER	S (mm)	L1 ±0,25 (mm)	L (mm)	Kg.
CWC 1000 010 V2	10	68	58	0.73
CWC 1000 013 V2	13	74	61	0.75
CWC 1000 016 V2	16	80	64	0.78
CWC 1000 019 V2	19	86	67	0.80
CWC 1000 025 V2	25	98	73	0.85
CWC 1000 032 V2	32	112	80	0.91
CWC 1000 038 V2	38	124	86	0.96
CWC 1000 050 V2	50	148	98	1.06
CWC 1000 063 V2	63	174	111	1.17
CWC 1000 075 V2	75	198	123	1.27
CWC 1000 080 V2	80	208	128	1.31
CWC 1000 100 V2	100	248	148	1.48
CWC 1000 125 V2	125	298	173	1.69

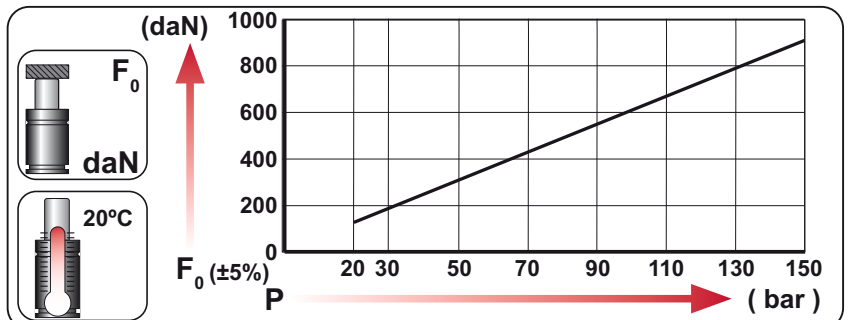

CODE	Image	Pressure		Force	
		bar	psi	daN	daN
CWC 1000 050 V2		150	2175	920	1505
CWC-H 1000 050 V2		0	0	---	---

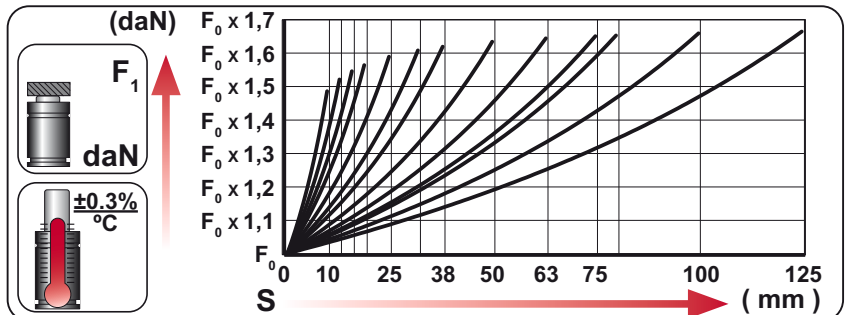

	ENG	ORDER		
	DEU	BESTELLUNG		
	FRA	COMMANDE		
	ITA	ORDINE		
	ESP	PEDIDO		
POR	PEDIDO			

**CWC 1000 50**

**CWC 1000 050 V2**

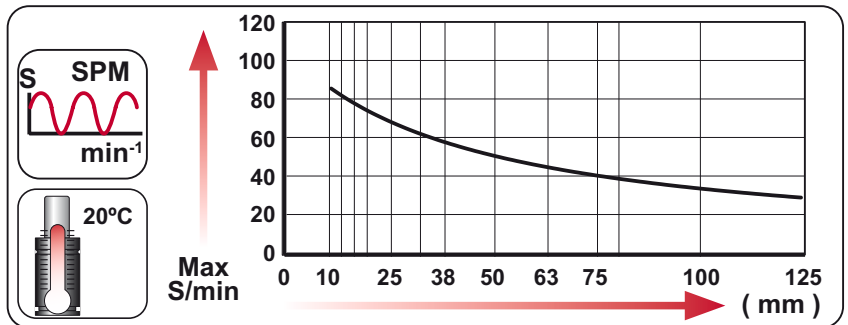

N <sub>2</sub>	Smax < 90%	Vmax 1,6 m/s	bar psi 20 290    bar psi 150 2175	°C °F 0 32    °C °F 80 176	600 CP-



# CWC 1000 V2

Compact Height

  	 <b>L1=148</b>	 <b>L1=138</b>
	<b>MODEL</b>	<b>CWC 1000</b>

<p><b>CW</b></p> <p><b>KRM6</b></p> <p><b>BK</b></p>	<p><b>CWC</b></p> <p><b>DRM8</b></p> <p><b>9RM8</b></p> <p><b>7RM8</b></p> <p><b>SKK</b></p> <p><b>TNRR</b></p> <p><b>MCRR</b></p> <p><b>TFRR</b></p> <p><b>SGS</b></p>
--	---

		<p><b>SEAL KIT S-XXXXXXX</b></p> <p><b>CARTRIDGE KIT C-XXXXXXX</b></p>		
--	--	--	--	--

CODE	CWC 1000 050 V2	KIT S-XXXXXXX KIT C-XXXXXXX	A14-050	18 CG 1-Q
ENG	ORDER	GAS SPRING	REPAIR KIT	FLANGE
DEU	BESTELLUNG	GASDRUCKFEDER	ERSATZTEILSATZ	FLANSCH
FRA	COMMANDE	RESSORT À GAZ	KIT DE RÉPARATION	BRIDE
ITA	ORDINE	CILINDRO AD AZOTO	KIT DI MANUTENZIONE	FLANGE
ESP	PEDIDO	RESORTE DE GAS	KIT DE REPARACION	BRIDA
POR	PEDIDO	CILINDRO DE GÁS	KIT DE MANUTENÇÃO	FLANGE
				CHARGING ADAPTER
				LADEADAPTER
				RACCORD DE CHARGE
				ADATTATORE DI CARICO
				ADAPTADOR DE CARGA
				ADAPTADOR DE CARGA

# CW/CWC 1000 V2 MOUNTS

Compact Height



### A14-050

ISO 9001 HAARLEM CEN E24.54.815.G EM24.54.700/F

### A34-050

ISO 9001 VDI

### B36-050

### B41-050

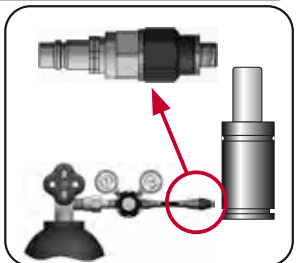
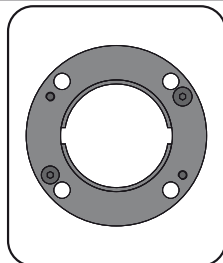
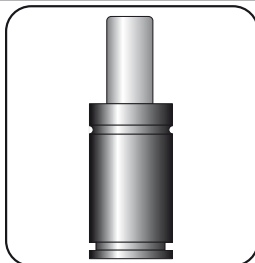
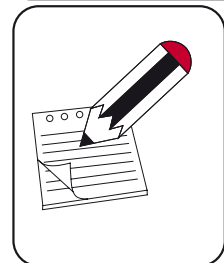

CODE	CWC 1000 050 V2	KIT S-XXXXXXX KIT C-XXXXXXX	A14-050	18 CG 1-Q
ENG ORDER	GAS SPRING	REPAIR KIT	FLANGE	CHARGING ADAPTER
DEU BESTELLUNG	GASDRUCKFEDER	ERSATZTEILSATZ	FLANSCH	LADEADAPTER
FRA COMMANDE	RESSORT À GAZ	KIT DE RÉPARATION	BRIDE	RACCORD DE CHARGE
ITA ORDINE	CILINDRO AD AZOTO	KIT DI MANUTENZIONE	FLANGE	ADATTATORE DI CARICO
ESP PEDIDO	RESORTE DE GAS	KIT DE REPARACION	BRIDA	ADAPTADOR DE CARGA
POR PEDIDO	CILINDRO DE GÁS	KIT DE MANUTENÇÃO	FLANGE	ADAPTADOR DE CARGA





# CW/CWC 1000 V2 MOUNTS

Compact Height

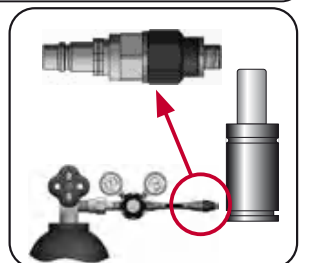
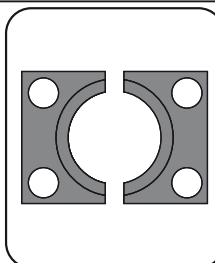
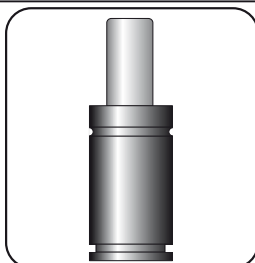
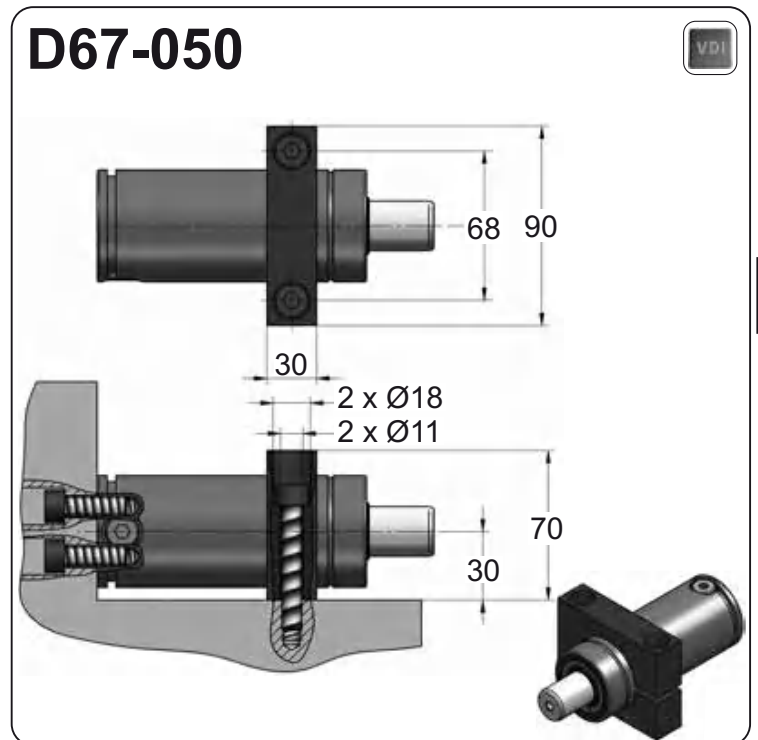
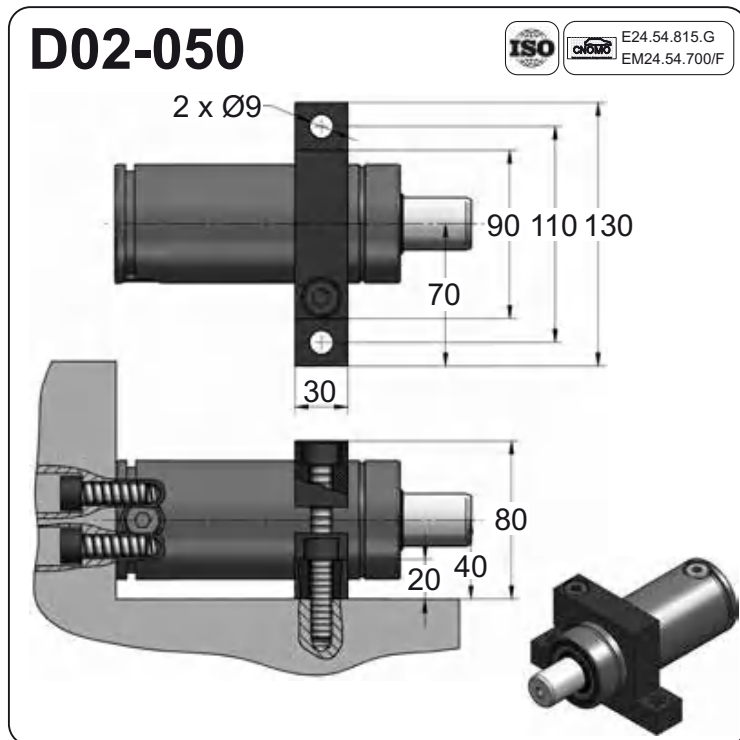
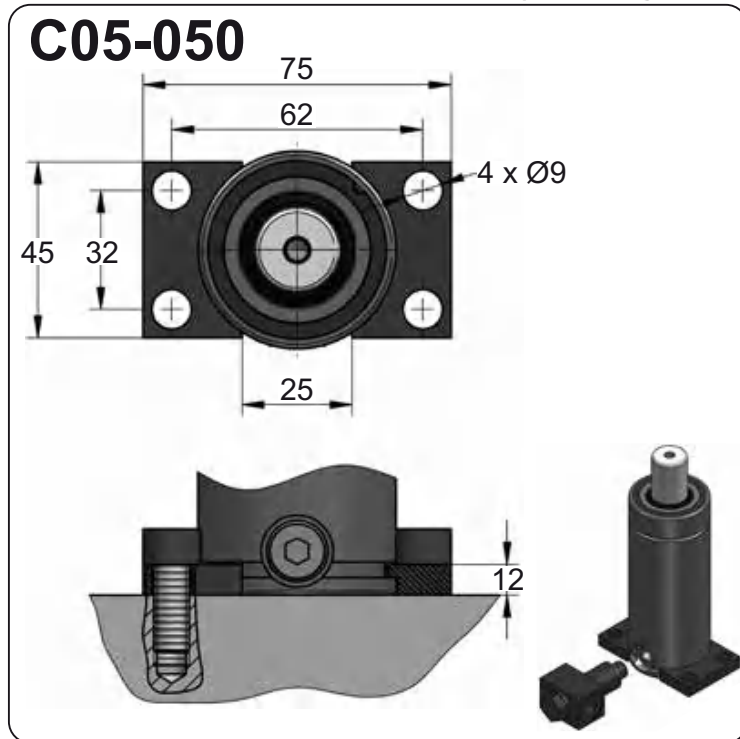

CODE	CWC 1000 050 V2	KIT S-XXXXXXX KIT C-XXXXXXX	C05-050	18 CG 1-Q
ENG	ORDER	GAS SPRING	REPAIR KIT	CHARGING ADAPTER
DEU	BESTELLUNG	GASDRUCKFEDER	ERSATZTEILSATZ	LADEADAPTER
FRA	COMMANDE	RESSORT À GAZ	KIT DE RÉPARATION	RACCORD DE CHARGE
ITA	ORDINE	CILINDRO AD AZOTO	KIT DI MANUTENZIONE	ADATTATORE DI CARICO
ESP	PEDIDO	RESORTE DE GAS	KIT DE REPARACION	ADAPTADOR DE CARGA
POR	PEDIDO	CILINDRO DE GÁS	KIT DE MANUTENÇÃO	ADAPTADOR DE CARGA

# CW 1500 V1

Compact Height



W B2 4005	FORD W-DX35-6204
B8 3180 220 000 004	
S0D 997	

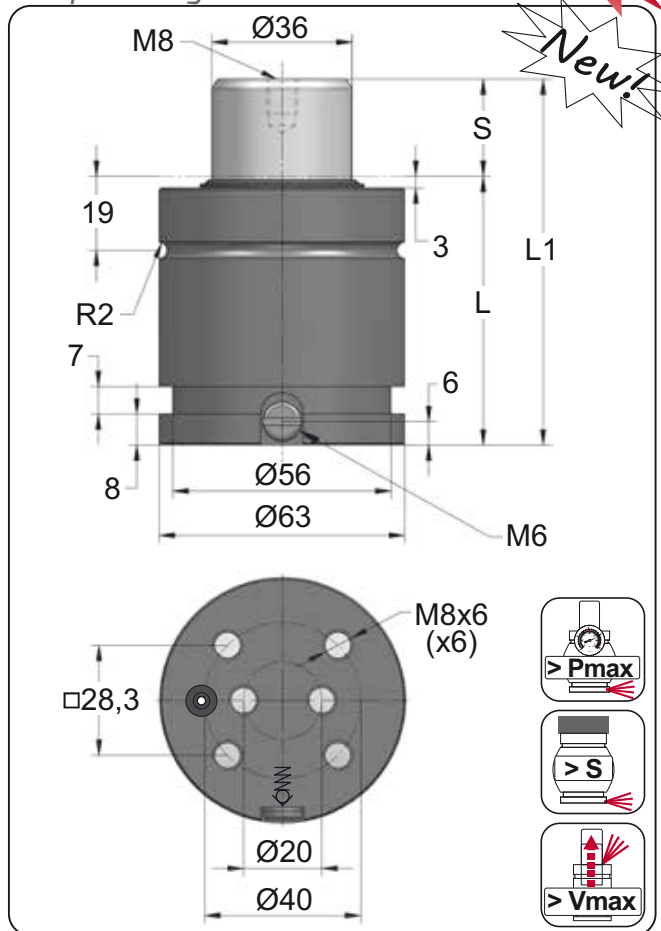

ORDER	S (mm)	L1 ±0.25 (mm)	L (mm)	Kg.
CW 1500 013 V1	13	70	57	0.99
CW 1500 016 V1	16	76	60	1.03
CW 1500 019 V1	19	82	63	1.07
CW 1500 025 V1	25	94	69	1.15
CW 1500 032 V1	32	108	76	1.24
CW 1500 038 V1	38	120	82	1.31
CW 1500 050 V1	50	144	94	1.47
CW 1500 063 V1	63	170	107	1.63
CW 1500 075 V1	75	194	119	1.79
CW 1500 080 V1	80	204	124	1.85
CW 1500 100 V1	100	244	144	2.11
CW 1500 125 V1	125	294	169	2.43

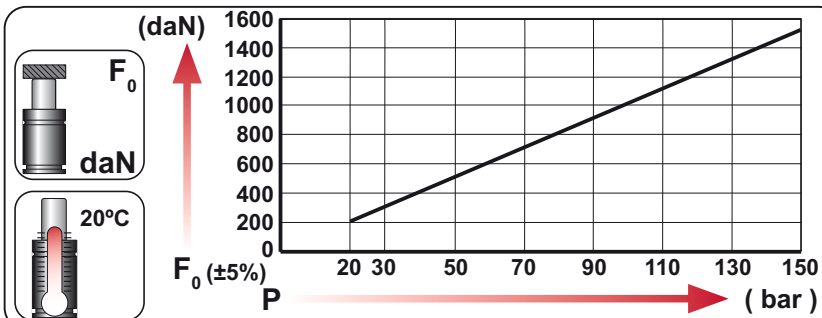

CODE	Image	Pressure		Force	
		bar	psi	daN	daN
CW 1500 050 V1		150	2175	1530	2475
CW-H 1500 050 V1		0	0	---	---

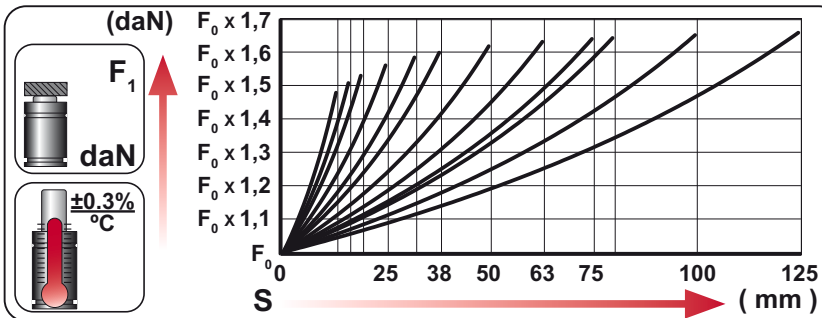

VDI 3003 **EQUIPPED WITH VDI - SAFETY**

Language	Order	Force (daN)	Stroke (mm)
ENG	ORDER	F <sub>0</sub>	S
DEU	BESTELLUNG	daN	mm
FRA	COMMANDE		
ITA	ORDINE		
ESP	PEDIDO		
POR	PEDIDO		
<b>CW 1500 050 V1</b>		<b>1500</b>	<b>50</b>

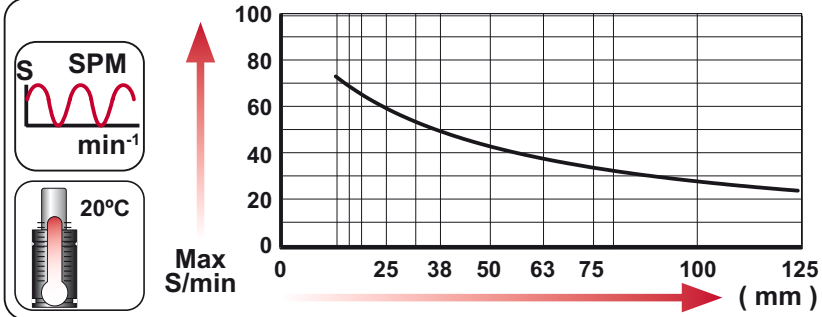

N <sub>2</sub>	S <sub>max</sub> < 90%	V <sub>max</sub> 1,6 m/s	P <sub>min</sub> (20°C) / P <sub>max</sub> (20°C)	T <sub>min</sub> / T <sub>max</sub>	600 CP-

N <sub>2</sub>	S <sub>max</sub> < 90%	V <sub>max</sub> 1,6 m/s	bar psi	bar psi	°C °F	°C °F	600 CP-
			20 290	150 2175	0 32	80 176	



# CW 1500 V1 MOUNTS

Compact Height

s mm Ø mm L1 mm		<p>50</p> <p>Ø63</p> <p>L1=144</p> <p>L1=152</p> <p>L1=152</p>		<p>50</p> <p>Ø63</p> <p>L1=152</p> <p>L1=160</p>	<p>50</p> <p>Ø63</p> <p>L1=185</p> <p>L1=195</p>		<p>50</p> <p>Ø63</p> <p>L1=175</p> <p>L1=190</p>	<p>50</p> <p>Ø63</p> <p>L1=205</p>
MODEL	X	CW 1500 KZ 1500 KT 1500	X	CT 1500 CK 1500	CM 1500 CD 1500		CPH 2800 CP 3000	CS 3000
SERIES	MINI 	COMPACT HEIGHT 	THREADED 	LOW PROFILE 	HEAVY DUTY 	ISO 	HEAVY LOAD 	POWER COMPACT STROKE 

### CW

KRM6

BK

### CWC

DRM8

TNRR

9RM8

MCRR

7RM8

TFRR

SKK

SGS

SEAL  
KIT S-XXXXXXX

CARTRIDGE  
KIT C-XXXXXXX

CODE	CW 1500 050 V1	KIT S-XXXXXXX KIT C-XXXXXXX	A14-063	06 CG 2-Q
ENG ORDER	GAS SPRING	REPAIR KIT	FLANGE	CHARGING ADAPTER
DEU BESTELLUNG	GASDRUCKFEDER	ERSATZTEILSATZ	FLANSCH	LADEADAPTER
FRA COMMANDE	RESSORT À GAZ	KIT DE RÉPARATION	BRIDE	RACCORD DE CHARGE
ITA ORDINE	CILINDRO AD AZOTO	KIT DI MANUTENZIONE	FLANGE	ADATTATORE DI CARICO
ESP PEDIDO	RESORTE DE GAS	KIT DE REPARACION	BRIDA	ADAPTADOR DE CARGA
POR PEDIDO	CILINDRO DE GÁS	KIT DE MANUTENÇÃO	FLANGE	ADAPTADOR DE CARGA

# CWC 1500

Compact Height

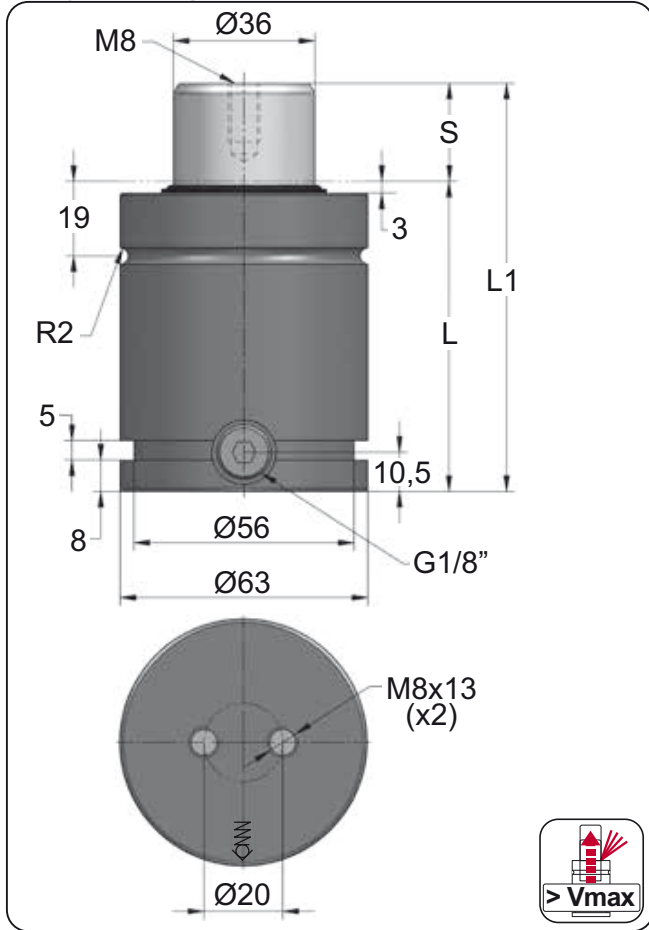

ORDER	S (mm)	L1 ±0,25 (mm)	L (mm)	Kg.
CWC 1500 013	13	80	67	1.22
CWC 1500 016	16	86	70	1.26
CWC 1500 019	19	92	73	1.30
CWC 1500 025	25	104	79	1.37
CWC 1500 032	32	118	86	1.46
CWC 1500 038	38	130	92	1.54
CWC 1500 050	50	154	104	1.70
CWC 1500 063	63	180	117	1.86
CWC 1500 075	75	204	129	2.02
CWC 1500 080	80	214	134	2.08
CWC 1500 100	100	254	154	2.34
CWC 1500 125	125	304	179	2.66

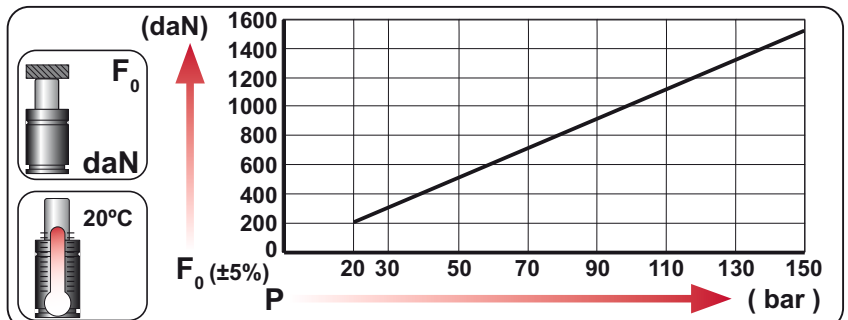

CODE	Image	Pressure		Force	
		bar	psi	daN	daN
CWC 1500 050		150	2175	1530	2475
CWC-H 1500 050		0	0	---	---

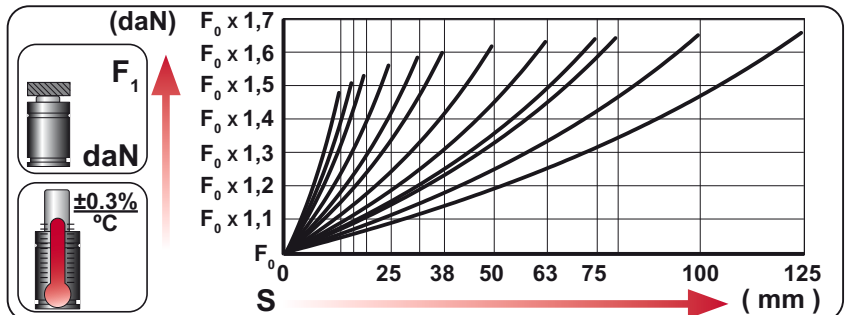

	ENG ORDER		
	DEU BESTELLUNG		
	FRA COMMANDE		
	ITA ORDINE		
	ESP PEDIDO		
POR PEDIDO			

**CWC 1500 50**

**CWC 1500 050**

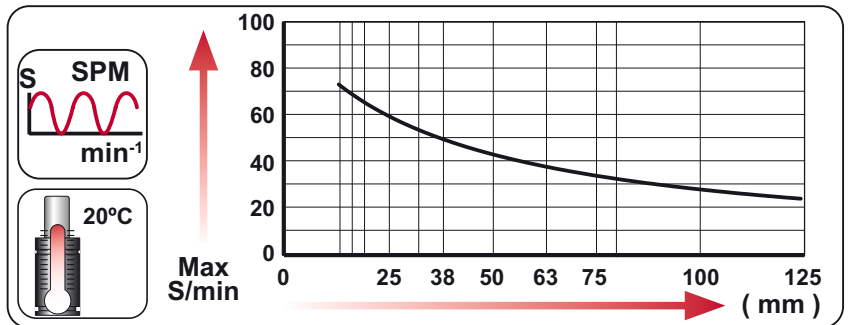

N <sub>2</sub>	S <sub>max</sub> < 90%	V <sub>max</sub> 1,6 m/s	bar psi	bar psi	°C °F	°C °F	600 CP-
			20 290	150 2175	0 32	80 176	





# CWC 1500

Compact Height

	MODEL	CWC 1500

<h3>CW</h3>	<h3>CWC</h3>
-------------	--------------

		<p>SEAL KIT S-XXXXXXX</p> <p>CARTRIDGE KIT C-XXXXXXX</p>		
--	--	--	--	--

CODE	CWC 1500 050	KIT S-XXXXXXX KIT C-XXXXXXX	A14-063	18 CG 1-Q
ENG	ORDER	GAS SPRING	REPAIR KIT	FLANGE
DEU	BESTELLUNG	GASDRUCKFEDER	ERSATZTEILSATZ	FLANSCH
FRA	COMMANDE	RESSORT À GAZ	KIT DE RÉPARATION	BRIDE
ITA	ORDINE	CILINDRO AD AZOTO	KIT DI MANUTENZIONE	FLANGE
ESP	PEDIDO	RESORTE DE GAS	KIT DE REPARACION	BRIDA
POR	PEDIDO	CILINDRO DE GÁS	KIT DE MANUTENÇÃO	FLANGE
				CHARGING ADAPTER
				LADEADAPTER
				RACCORD DE CHARGE
				ADATTATORE DI CARICO
				ADAPTADOR DE CARGA
				ADAPTADOR DE CARGA

# CW 1500 V1 /CWC 1500 MOUNTS

Compact Height

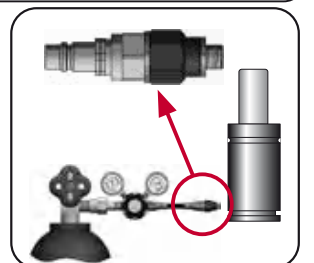
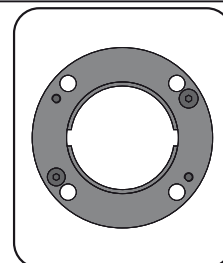
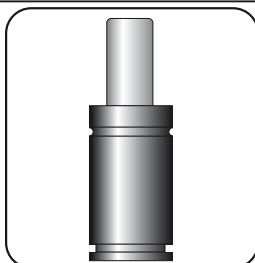
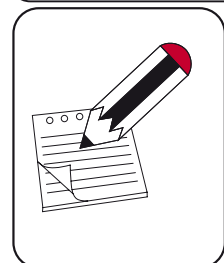
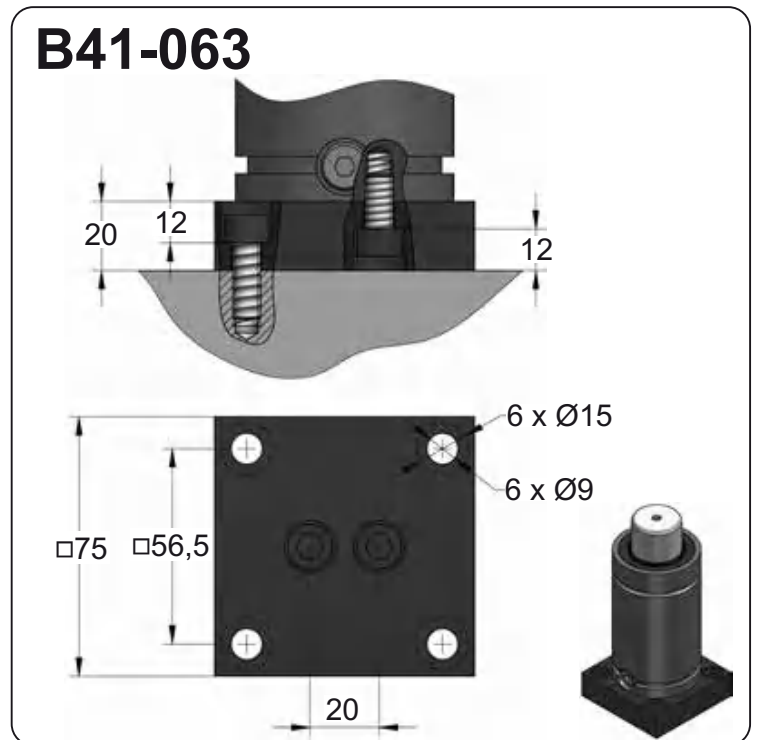
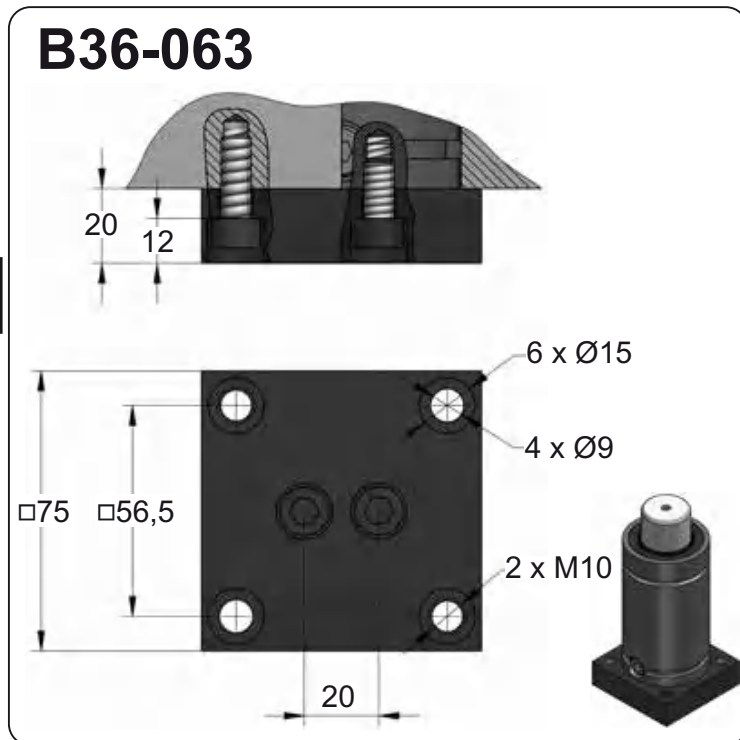
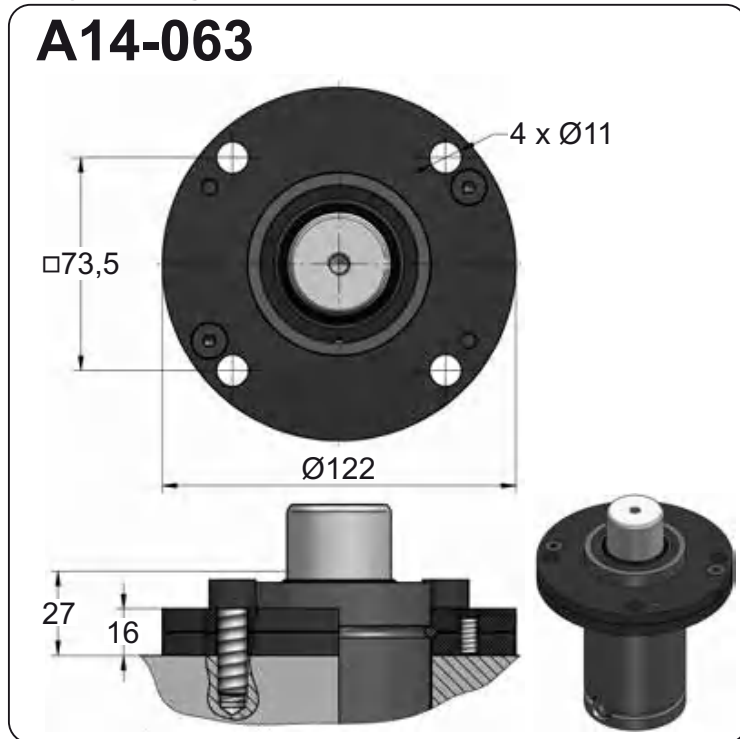

CODE	CWC 1500 050	KIT S-XXXXXXX KIT C-XXXXXXX	A14-063	18 CG 1-Q
ENG ORDER	GAS SPRING	REPAIR KIT	FLANGE	CHARGING ADAPTER
DEU BESTELLUNG	GASDRUCKFEDER	ERSATZTEILSATZ	FLANSCH	LADEADAPTER
FRA COMMANDE	RESSORT À GAZ	KIT DE RÉPARATION	BRIDE	RACCORD DE CHARGE
ITA ORDINE	CILINDRO AD AZOTO	KIT DI MANUTENZIONE	FLANGE	ADATTATORE DI CARICO
ESP PEDIDO	RESORTE DE GAS	KIT DE REPARACION	BRIDA	ADAPTADOR DE CARGA
POR PEDIDO	CILINDRO DE GÁS	KIT DE MANUTENÇÃO	FLANGE	ADAPTADOR DE CARGA



# CW 1500 V1/CWC 1500 MOUNTS

Compact Height

## C05-063

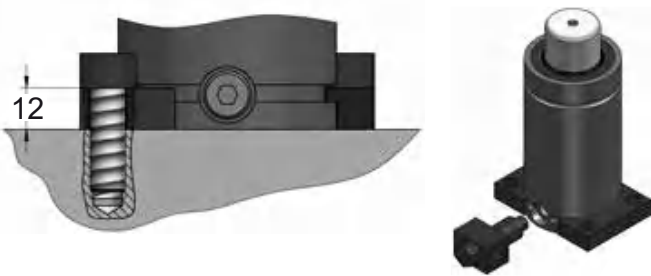
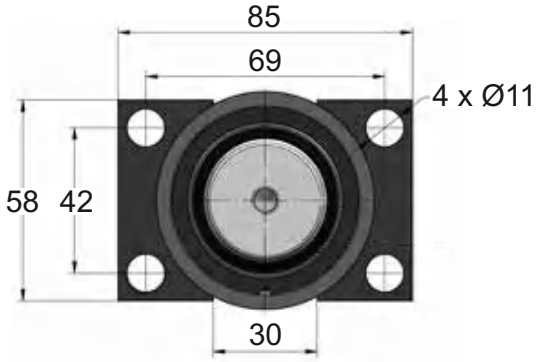

## C35-063

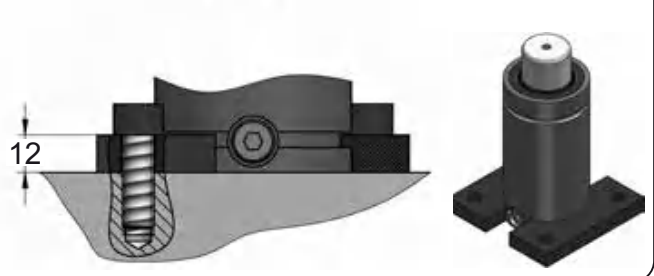
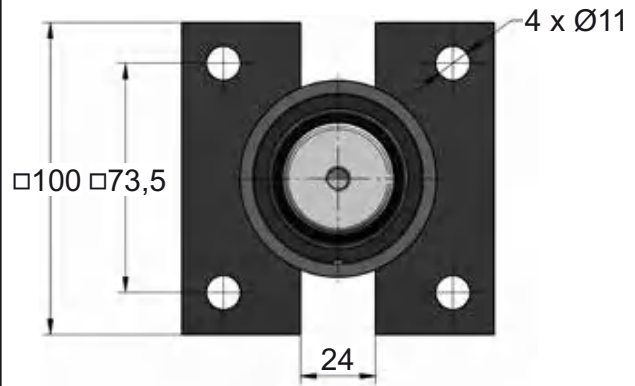

## D02-063

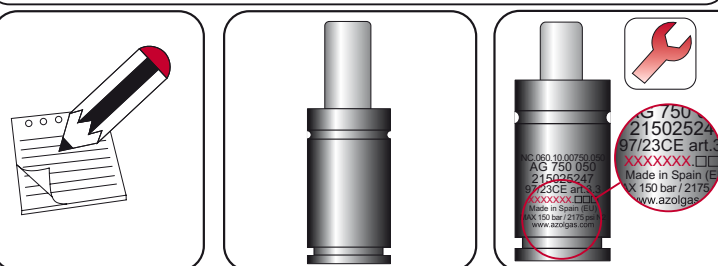
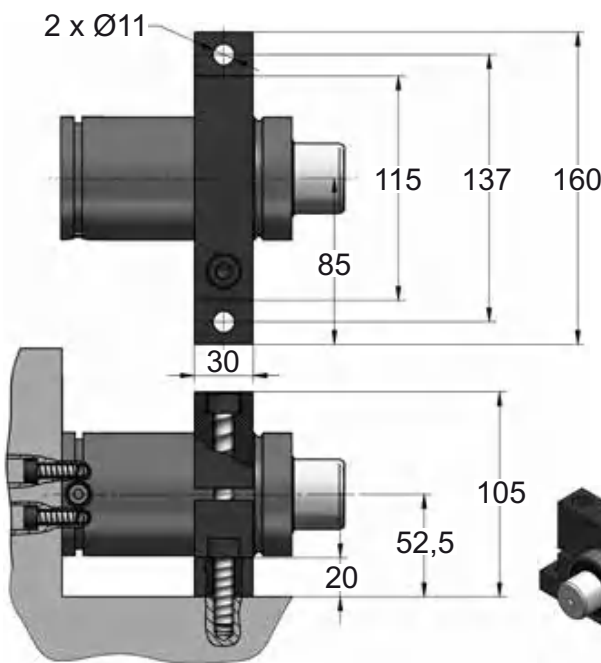

## D67-063

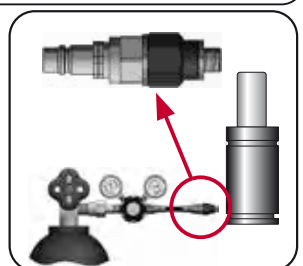
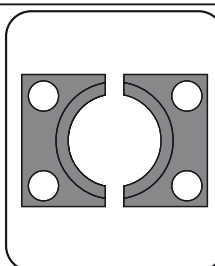
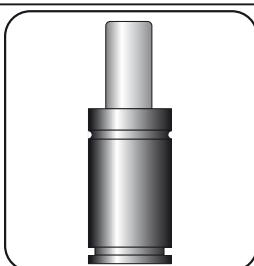
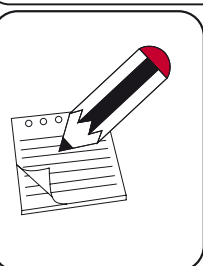
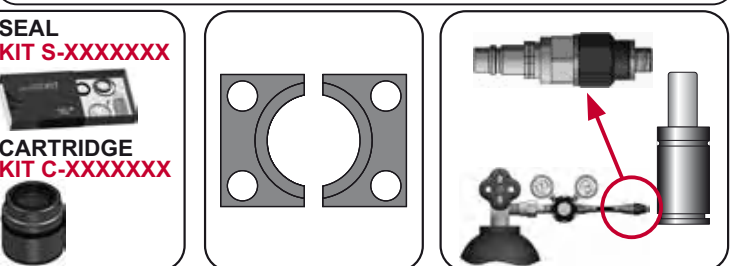
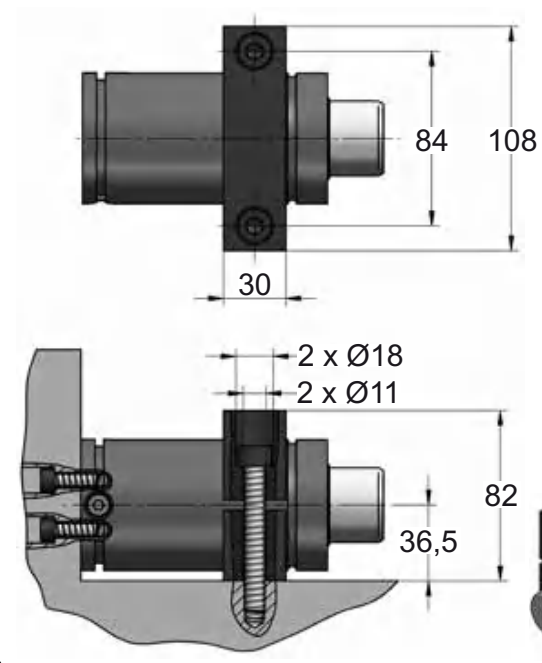

CODE	CWC 1500 050	KIT S-XXXXXXX KIT C-XXXXXXX	C05-063	18 CG 1-Q
ENG ORDER	GAS SPRING	REPAIR KIT	FLANGE	CHARGING ADAPTER
DEU BESTELLUNG	GASDRUCKFEDER	ERSATZTEILSATZ	FLANSCH	LADEADAPTER
FRA COMMANDE	RESSORT À GAZ	KIT DE RÉPARATION	BRIDE	RACCORD DE CHARGE
ITA ORDINE	CILINDRO AD AZOTO	KIT DI MANUTENZIONE	FLANGE	ADATTATORE DI CARICO
ESP PEDIDO	RESORTE DE GAS	KIT DE REPARACION	BRIDA	ADAPTADOR DE CARGA
POR PEDIDO	CILINDRO DE GÁS	KIT DE MANUTENÇÃO	FLANGE	ADAPTADOR DE CARGA

# CW 2400 V1

Compact Height

BMW B2 4005	FORD W-DX35-6204	PSA E24.54.815.G
MB B8 3180 220 000 004	GM 90.25.08	
VW 39D 997		

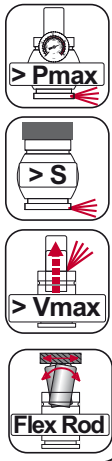
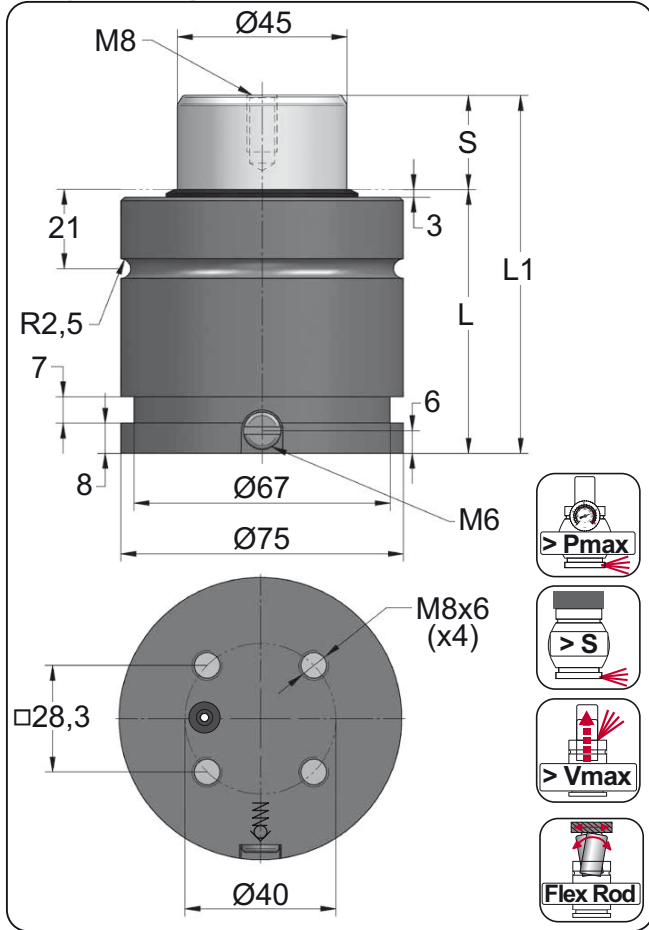

ORDER	S (mm)	L1 ±0.25 (mm)	L (mm)	Kg.
CW 2400 013 V1	13	71	58	1.41
CW 2400 016 V1	16	77	61	1.46
CW 2400 019 V1	19	83	64	1.51
CW 2400 025 V1	25	95	70	1.62
CW 2400 032 V1	32	109	77	1.74
CW 2400 038 V1	38	121	83	1.84
CW 2400 050 V1	50	145	95	2.05
CW 2400 063 V1	63	171	108	2.27
CW 2400 075 V1	75	195	120	2.47
CW 2400 080 V1	80	205	125	2.56
CW 2400 100 V1	100	245	145	2.90
CW 2400 125 V1	125	295	170	3.33



CODE	Image	Pressure		Force	
		bar	psi	daN	daN
CW 2400 050 V1		150	2175	2385	3890
CW-H 2400 050 V1		0	0	---	---

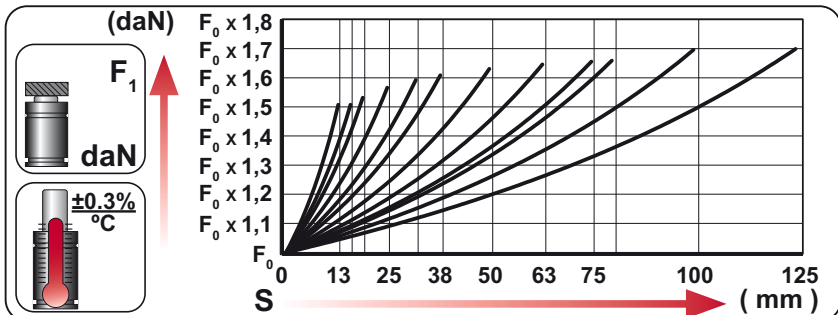
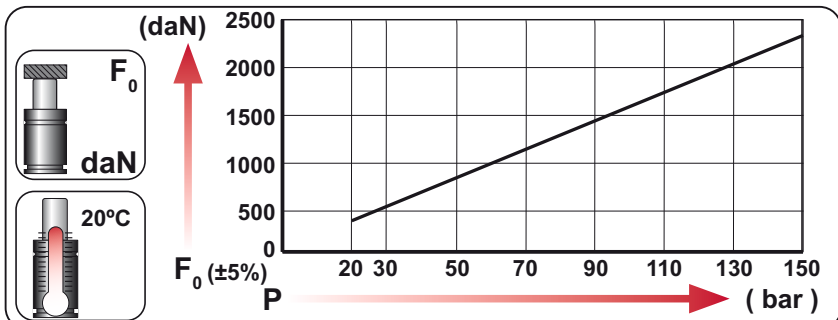

**EQUIPPED WITH VDI - SAFETY**

Language	Order	Force (daN)	Stroke (mm)
ENG	ORDER	F <sub>0</sub>	S
DEU	BESTELLUNG	daN	mm
FRA	COMMANDE		
ITA	ORDINE		
ESP	PEDIDO		
POR	PEDIDO		
<b>CW 2400 050 V1</b>		<b>2400</b>	<b>50</b>

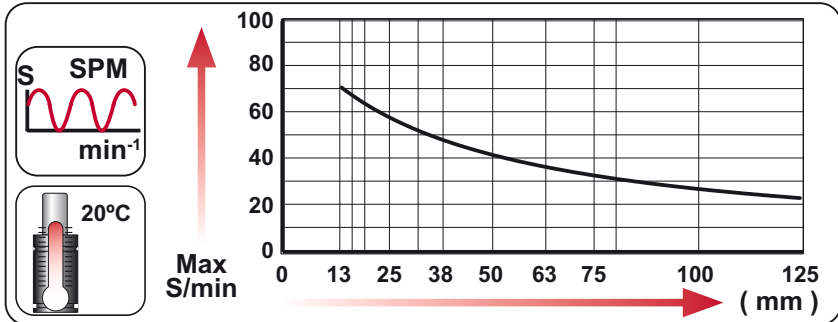

--	--	--	--	--	--

N <sub>2</sub>	Smax < 90%	Vmax 1,6 m/s	bar psi	bar psi	°C °F	°C °F	600 CP-
			20 290	150 2175	0 32	80 176	





# CW 2400 V1

Compact Height

s mm Ø mm L1 mm		50  Ø75 L1=145 L1=159 L1=159		50  Ø75 L1=154 L1=160 L1=160	50  Ø75 L1=185 L1=195 L1=210	50  Ø75 L1=210	50  Ø75 L1=175 L1=200	50  Ø75 L1=240
MODEL	X	CW 2400 KZ 2400 KT 2400	X	CT 2500 CK 2500 FD 1500	GN 1500 CM 2500 CD 2400	AG 1500	CPH 4300 CP 5000	CS 4700
SERIES	MINI 	COMPACT HEIGHT 	THREADED 	LOW PROFILE 	HEAVY DUTY 	ISO 	HEAVY LOAD 	POWER COMPACT STROKE 

<h2>CW</h2>	<h2>CWC</h2>	DRM8 	TNRR 
KRM6 	BK 	9RM8 	MCRR 
7RM8 	TFRR 	SKK 	SGS 

		 SEAL KIT S-XXXXXXX  CARTRIDGE KIT C-XXXXXXX 		
--	--	---	--	--

CODE	CW 2400 050 V1	KIT S-XXXXXXX KIT C-XXXXXXX	A14-075	06 CG 2-Q
ENG ORDER	GAS SPRING	REPAIR KIT	FLANGE	CHARGING ADAPTER
DEU BESTELLUNG	GASDRUCKFEDER	ERSATZTEILSATZ	FLANSCHEN	LADEADAPTER
FRA COMMANDE	RESSORT À GAZ	KIT DE RÉPARATION	BRIDE	RACCORD DE CHARGE
ITA ORDINE	CILINDRO AD AZOTO	KIT DI MANUTENZIONE	FLANGE	ADATTATORE DI CARICO
ESP PEDIDO	RESORTE DE GAS	KIT DE REPARACION	BRIDA	ADAPTADOR DE CARGA
POR PEDIDO	CILINDRO DE GÁS	KIT DE MANUTENÇÃO	FLANGE	ADAPTADOR DE CARGA

# CWC 2400 V2

Compact Height

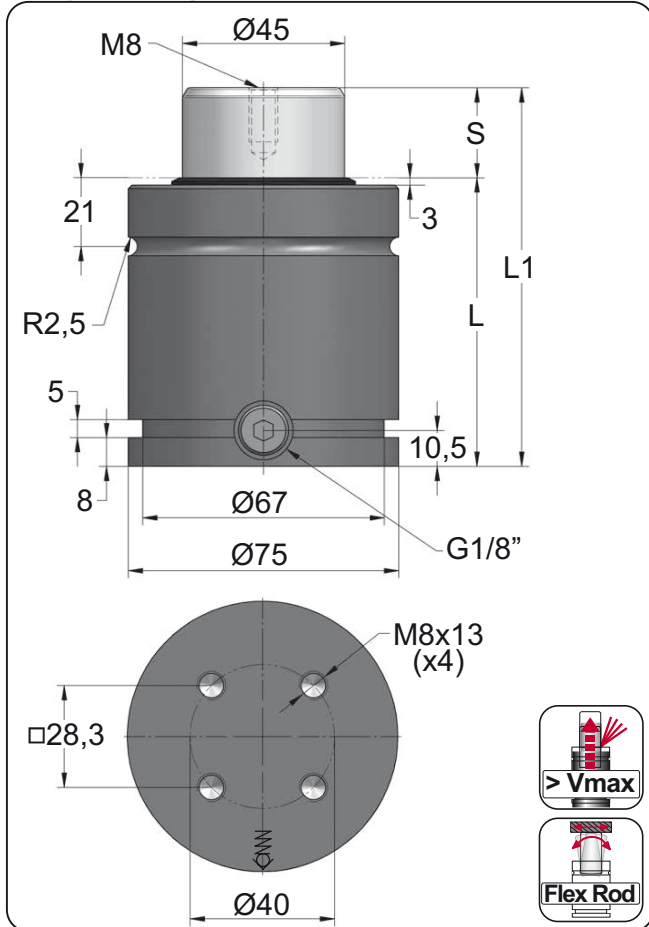

ORDER	S (mm)	L1 ±0,25 (mm)	L (mm)	Kg.
CWC 2400 013 V2	13	81	68	1.73
CWC 2400 016 V2	16	87	71	1.78
CWC 2400 019 V2	19	93	74	1.84
CWC 2400 025 V2	25	105	80	1.94
CWC 2400 032 V2	32	119	87	2.06
CWC 2400 038 V2	38	131	93	2.16
CWC 2400 050 V2	50	155	105	2.37
CWC 2400 063 V2	63	181	118	2.59
CWC 2400 075 V2	75	205	130	2.80
CWC 2400 080 V2	80	215	135	2.88
CWC 2400 100 V2	100	255	155	3.22
CWC 2400 125 V2	125	305	180	3.65

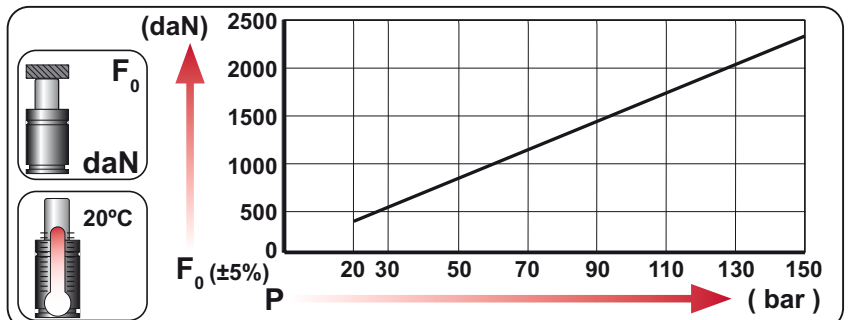

CODE	Image	Pressure		Force	
		bar	psi	daN	daN
CWC 2400 050 V2		150	2175	2385	3890
CWC-H 2400 050 V2		0	0	---	---

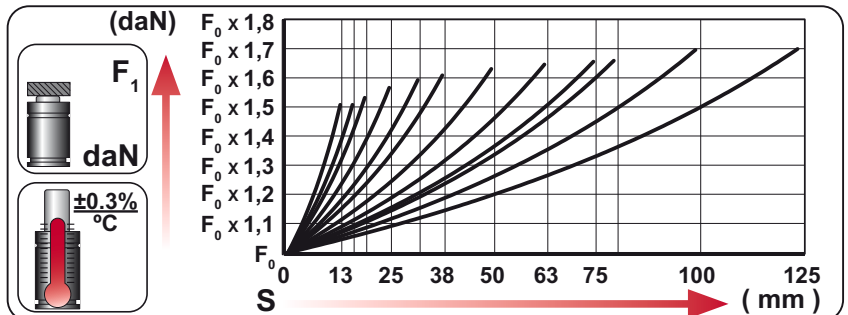

Language	Order Code	Force F0 (daN)	Stroke S (mm)
ENG	ORDER	F0	S
DEU	BESTELLUNG	daN	mm
FRA	COMMANDE		
ITA	ORDINE		
ESP	PEDIDO		
POR	PEDIDO		

**CWC 2400 50**

**CWC 2400 050 V2**

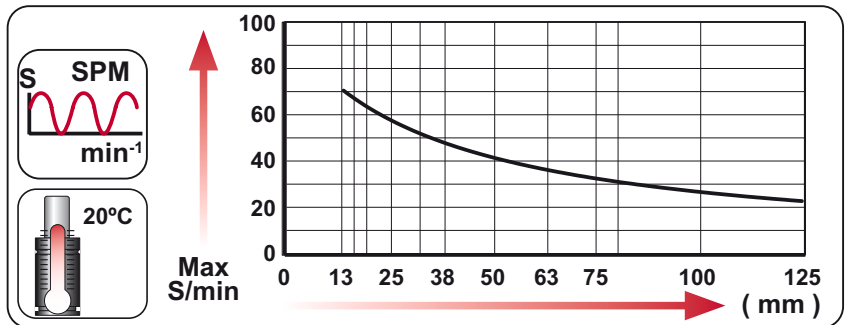

			bar psi	bar psi	°C °F	°C °F	600 CP-
N <sub>2</sub>	Smax < 90%	Vmax 1,6 m/s	20 290	150 2175	0 32	80 176	600 CP-



# CWC 2400 V2

Compact Height

MODEL	CWC 2400	CW 2400

<p><b>CW</b></p>	<p><b>CWC</b></p>
<p><b>KRM6</b></p>	<p><b>BK</b></p>
<p><b>DRM8</b></p>	<p><b>TNRR</b></p>
<p><b>9RM8</b></p>	<p><b>MCRR</b></p>
<p><b>7RM8</b></p>	<p><b>TFRR</b></p>
<p><b>SKK</b></p>	<p><b>SGS</b></p>

		<p><b>SEAL KIT S-XXXXXXX</b></p>	<p><b>CARTRIDGE KIT C-XXXXXXX</b></p>		
--	--	----------------------------------	---------------------------------------	--	--

CODE	CWC 2400 050 V2	KIT S-XXXXXXX KIT C-XXXXXXX	A14-075	18 CG 1-Q
ENG	ORDER	GAS SPRING	REPAIR KIT	FLANGE
DEU	BESTELLUNG	GASDRUCKFEDER	ERSATZTEILSATZ	FLANSCH
FRA	COMMANDE	RESSORT À GAZ	KIT DE RÉPARATION	BRIDE
ITA	ORDINE	CILINDRO AD AZOTO	KIT DI MANUTENZIONE	FLANGE
ESP	PEDIDO	RESORTE DE GAS	KIT DE REPARACION	BRIDA
POR	PEDIDO	CILINDRO DE GÁS	KIT DE MANUTENÇÃO	FLANGE
				CHARGING ADAPTER
				LADEADAPTER
				RACCORD DE CHARGE
				ADATTATORE DI CARICO
				ADAPTADOR DE CARGA
				ADAPTADOR DE CARGA

# CW 2400 V1 /CWC 2400 V2 MOUNTS



Compact Height

### A14-075

ISO 9001 HAARLEM CENOC E24.54.815.G EM24.54.700/F

### A34-075

ISO 9001 VDI

### B36-075

### B41-075

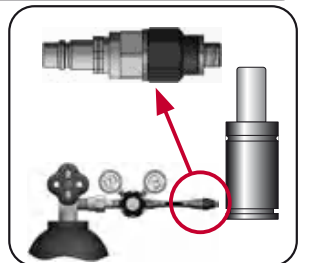
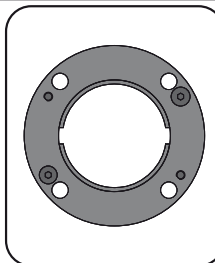
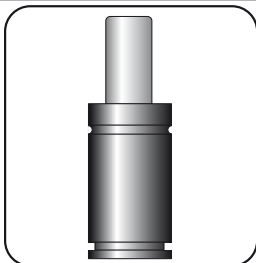

CODE	CWC 2400 050 V2	KIT S-XXXXXXX KIT C-XXXXXXX	A14-075	18 CG 1-Q
ENG ORDER	GAS SPRING	REPAIR KIT	FLANGE	CHARGING ADAPTER
DEU BESTELLUNG	GASDRUCKFEDER	ERSATZTEILSATZ	FLANSCH	LADEADAPTER
FRA COMMANDE	RESSORT À GAZ	KIT DE RÉPARATION	BRIDE	RACCORD DE CHARGE
ITA ORDINE	CILINDRO AD AZOTO	KIT DI MANUTENZIONE	FLANGE	ADATTATORE DI CARICO
ESP PEDIDO	RESORTE DE GAS	KIT DE REPARACION	BRIDA	ADAPTADOR DE CARGA
POR PEDIDO	CILINDRO DE GÁS	KIT DE MANUTENÇÃO	FLANGE	ADAPTADOR DE CARGA





# CW 2400 V1/CWC 2400 V2 MOUNTS

Compact Height

### C05-075

### C20-075

### D02-075

2 x Ø11

### D67-075

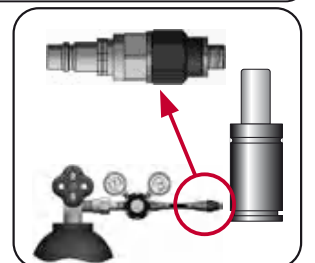
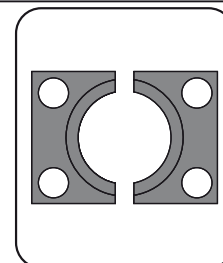
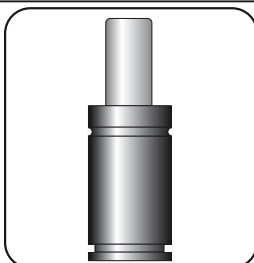

CODE	CWC 2400 050 V2	KIT S-XXXXXXX KIT C-XXXXXXX	C05-075	18 CG 1-Q
ENG	ORDER	GAS SPRING	REPAIR KIT	CHARGING ADAPTER
DEU	BESTELLUNG	GASDRUCKFEDER	ERSATZTEILSATZ	LADEADAPTER
FRA	COMMANDE	RESSORT À GAZ	KIT DE RÉPARATION	RACCORD DE CHARGE
ITA	ORDINE	CILINDRO AD AZOTO	KIT DI MANUTENZIONE	ADATTATORE DI CARICO
ESP	PEDIDO	RESORTE DE GAS	KIT DE REPARACION	ADAPTADOR DE CARGA
POR	PEDIDO	CILINDRO DE GÁS	KIT DE MANUTENÇÃO	ADAPTADOR DE CARGA

# CW 4200 V1

Compact Height

BMW B2 4005	FORD W-DX35-6204	PSA E24.54.815.G
MB B8 3180 220 000 004	GM 90.25.08	
VW 39D 997		

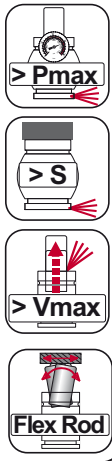
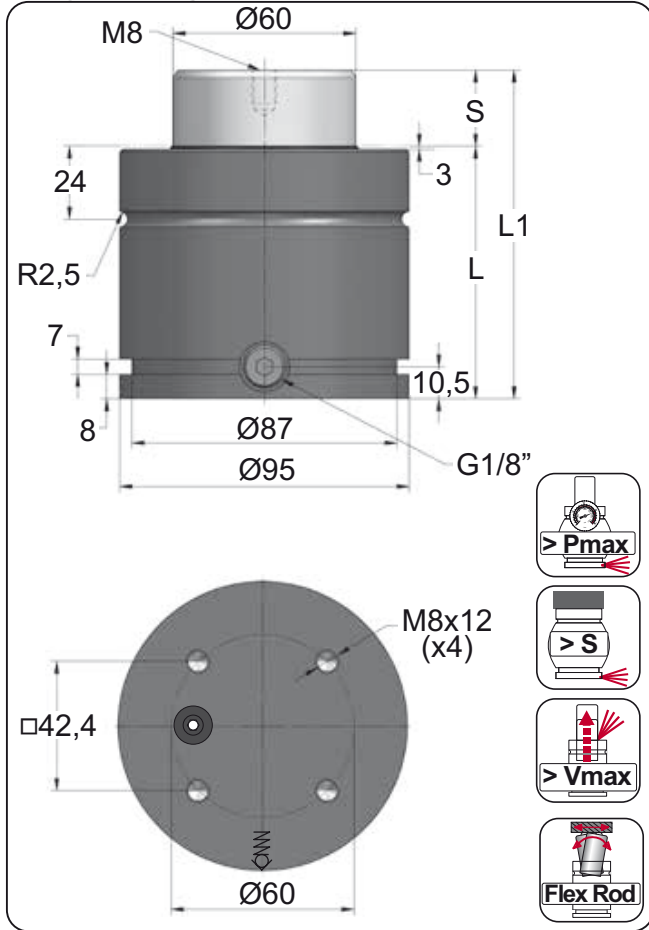

ORDER	S (mm)	L1 ±0.25 (mm)	L (mm)	Kg.
CW 4200 016 V1	16	90	74	3.03
CW 4200 019 V1	19	96	77	3.11
CW 4200 025 V1	25	108	83	3.29
CW 4200 032 V1	32	122	90	3.49
CW 4200 038 V1	38	134	96	3.66
CW 4200 050 V1	50	158	108	4.00
CW 4200 063 V1	63	184	121	4.37
CW 4200 075 V1	75	208	133	4.71
CW 4200 080 V1	80	218	138	4.85
CW 4200 100 V1	100	258	158	5.42
CW 4200 125 V1	125	308	183	6.14



CODE	Image	Pressure		Force	
		bar	psi	daN	daN
CW 4200 050 V1		150	2175	4240	7200
CW-H 4200 050 V1		0	0	---	---

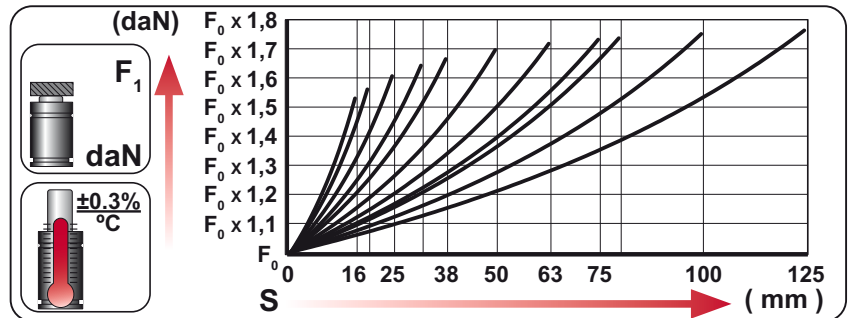
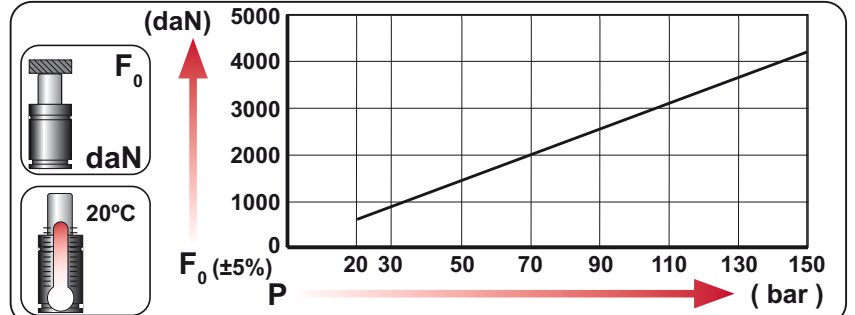

**EQUIPPED WITH VDI - SAFETY**

Language	Order Type	Force (daN)	Stroke (mm)
ENG ORDER	DEU BESTELLUNG		
FRA COMMANDE	ITA ORDINE	4200	50
ESP PEDIDO	POR PEDIDO		

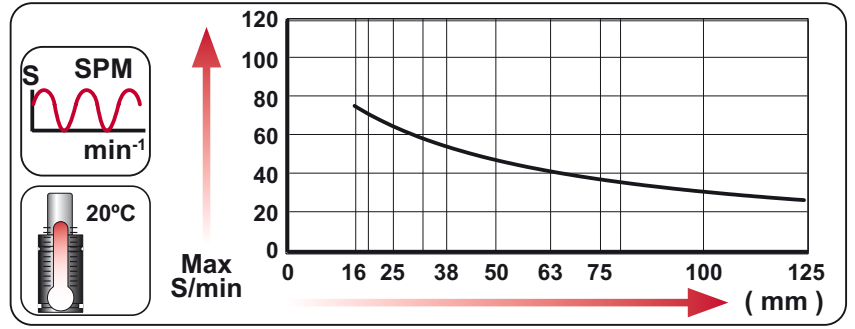

N <sub>2</sub>	S <sub>max</sub> < 90%	V <sub>max</sub> 1,6 m/s	P <sub>min</sub> (20°C)	P <sub>max</sub> (20°C)	T <sub>min</sub>	T <sub>max</sub>	600 CP-

bar	psi	bar	psi	°C	°F	°C	°F
20	290	150	2175	0	32	80	176



# CW 4200 V1 MOUNTS

Compact Height

s mm Ø mm L1 mm		<p>50</p> <p>Ø95</p> <p>L1=158</p> <p>L1=162</p> <p>L1=162</p>		<p>50</p> <p>Ø95</p> <p>L1=170</p> <p>L1=170</p>	<p>50</p> <p>Ø95</p> <p>L1=195</p> <p>L1=205</p> <p>L1=220</p>	<p>50</p> <p>Ø95</p> <p>L1=220</p>	<p>50</p> <p>Ø95</p> <p>L1=215</p>	<p>50</p> <p>Ø95</p> <p>L1=255</p>
MODEL	X	CW 4200 KZ 4200 KT 4200	X	CK 4000 FD 3000	GN 3000 CM 4000 CD 4200	AG 3000	CP 8000	CS 7500
SERIES	MINI	COMPACT HEIGHT	THREADED	LOW PROFILE	HEAVY DUTY	ISO	HEAVY LOAD	POWER COMPACT STROKE

## A14-095

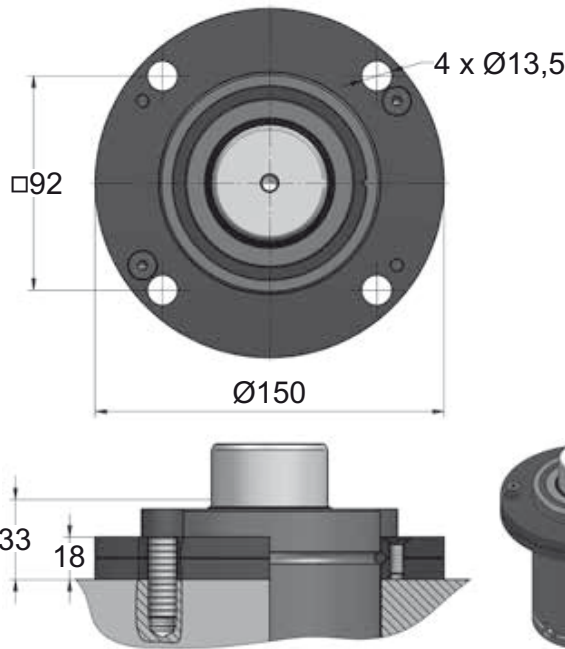

## A34-095

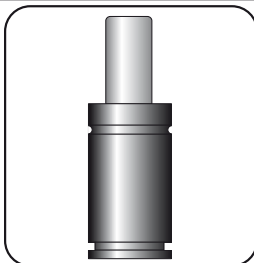
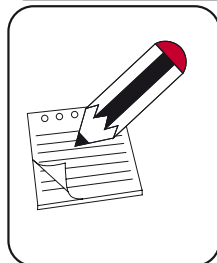
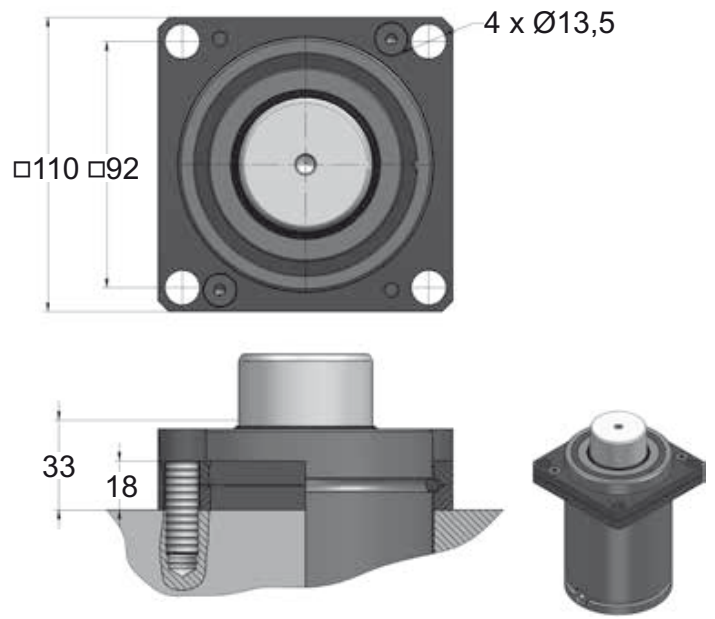

SEAL  
KIT S-XXXXXXX



CARTRIDGE  
KIT C-XXXXXXX

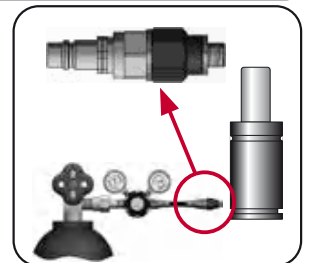
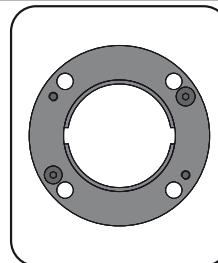

CODE	CW 4200 050 V1	KIT S-XXXXXXX KIT C-XXXXXXX	A14-095	18 CG 1-Q
ENG ORDER	GAS SPRING	REPAIR KIT	FLANGE	CHARGING ADAPTER
DEU BESTELLUNG	GASDRUCKFEDER	ERSATZTEILSATZ	FLANSCH	LADEADAPTER
FRA COMMANDE	RESSORT À GAZ	KIT DE RÉPARATION	BRIDE	RACCORD DE CHARGE
ITA ORDINE	CILINDRO AD AZOTO	KIT DI MANUTENZIONE	FLANGE	ADATTATORE DI CARICO
ESP PEDIDO	RESORTE DE GAS	KIT DE REPARACION	BRIDA	ADAPTADOR DE CARGA
POR PEDIDO	CILINDRO DE GÁS	KIT DE MANUTENÇÃO	FLANGE	ADAPTADOR DE CARGA

# CW 4200 V1 MOUNTS

Compact Height



## B36-095

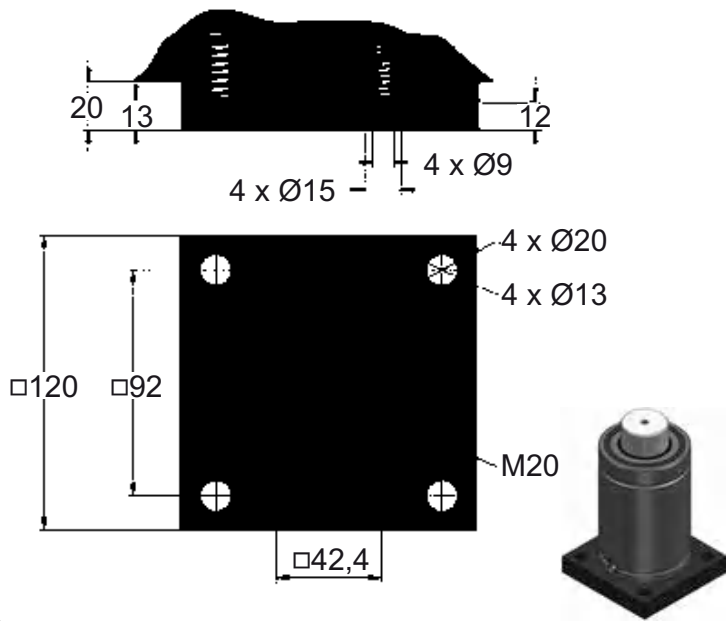

## B41-095

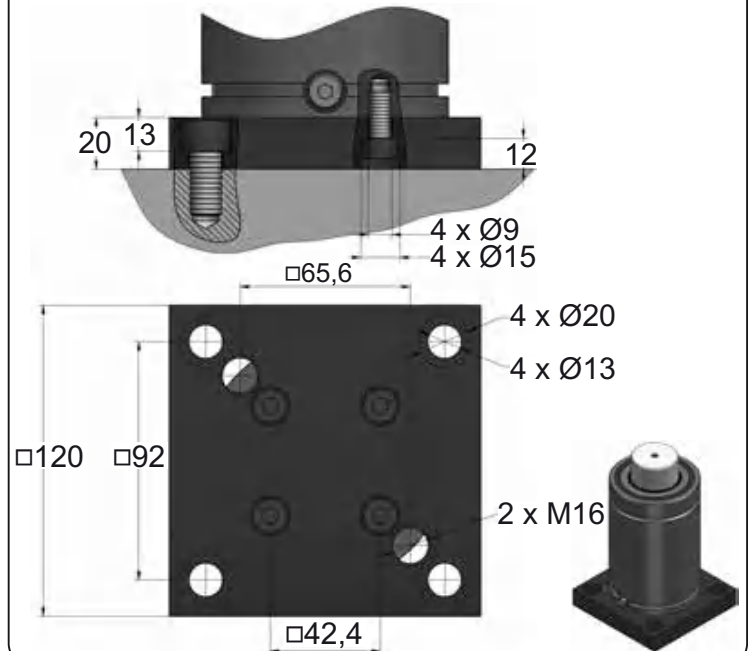

## C05-095

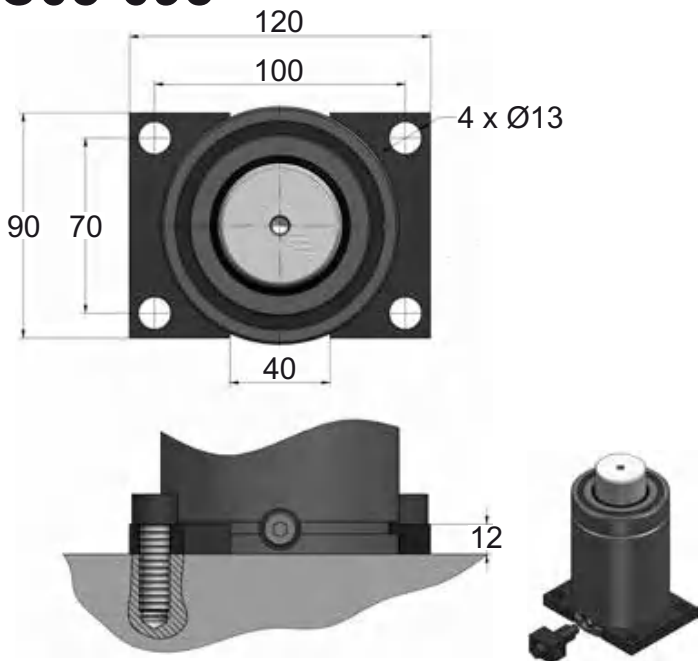

## C20-095

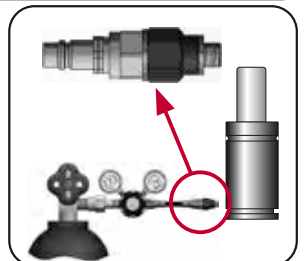
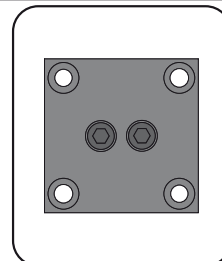
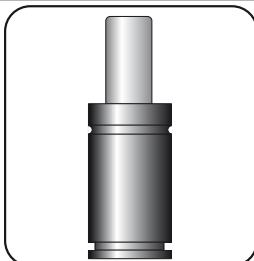
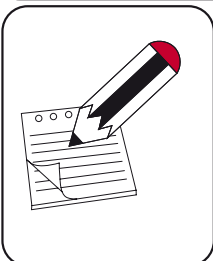
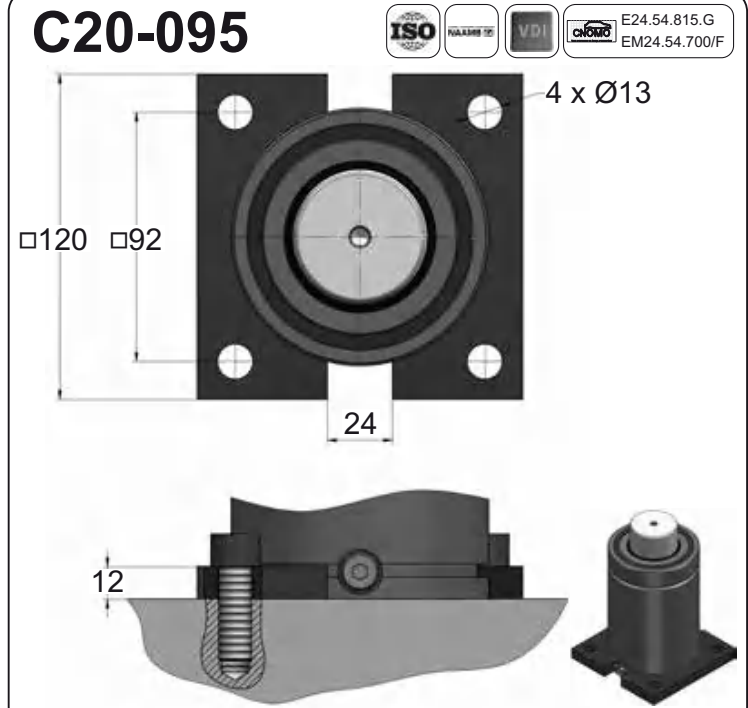

CODE	CW 4200 050 V1	KIT S-XXXXXXX KIT C-XXXXXXX	B36-095	18 CG 1-Q
ENG	ORDER	GAS SPRING	REPAIR KIT	CHARGING ADAPTER
DEU	BESTELLUNG	GASDRUCKFEDER	ERSATZTEILSATZ	LADEADAPTER
FRA	COMMANDE	RESSORT À GAZ	KIT DE RÉPARATION	RACCORD DE CHARGE
ITA	ORDINE	CILINDRO AD AZOTO	KIT DI MANUTENZIONE	ADATTATORE DI CARICO
ESP	PEDIDO	RESORTE DE GAS	KIT DE REPARACION	ADAPTADOR DE CARGA
POR	PEDIDO	CILINDRO DE GÁS	KIT DE MANUTENÇÃO	ADAPTADOR DE CARGA





# CW 4200 V1 MOUNTS

Compact Height

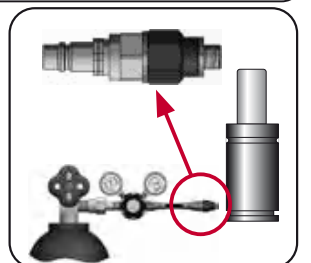
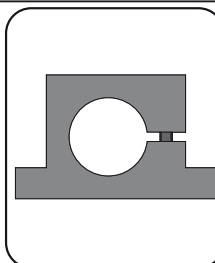
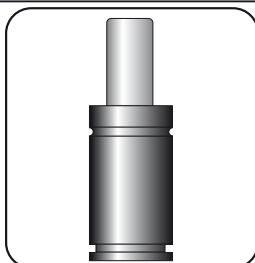
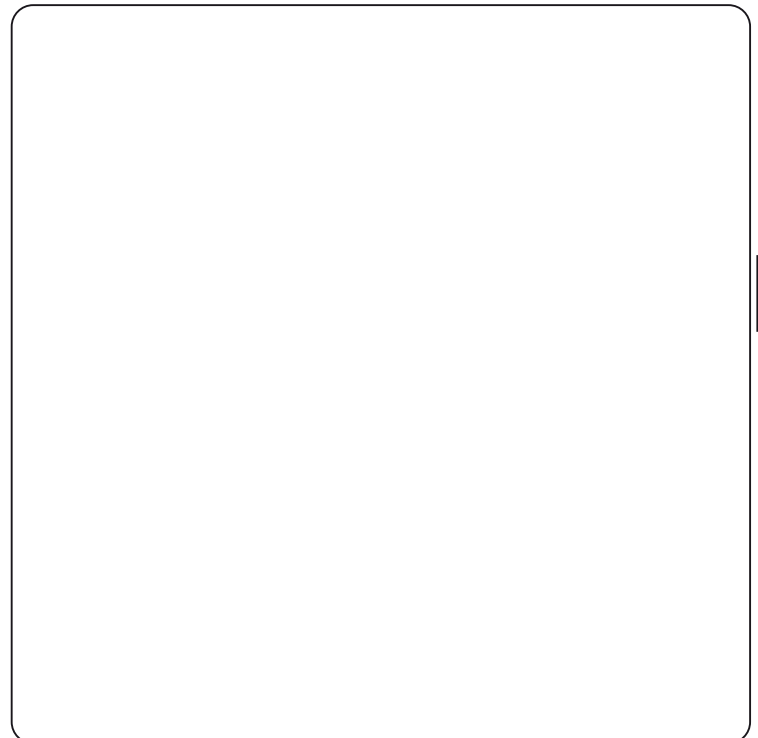
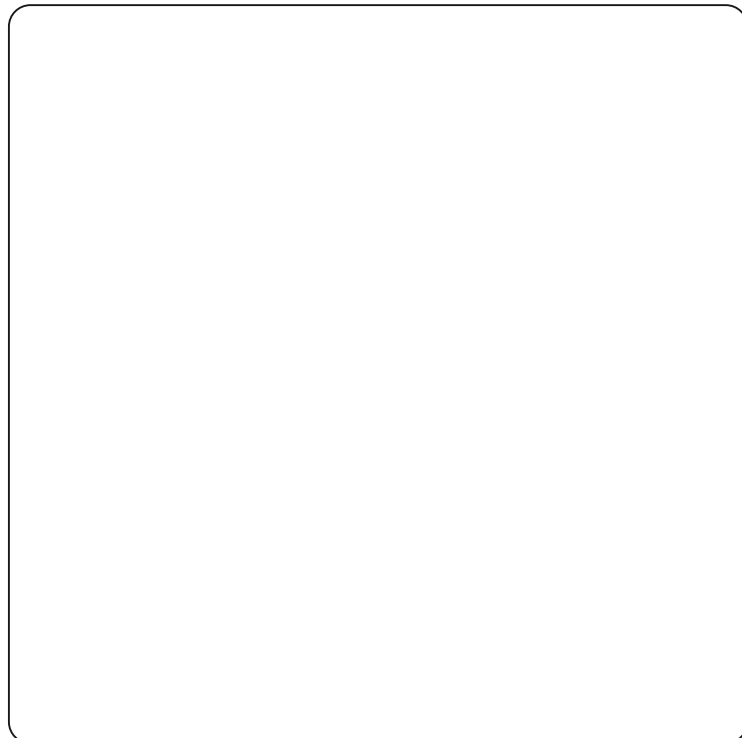
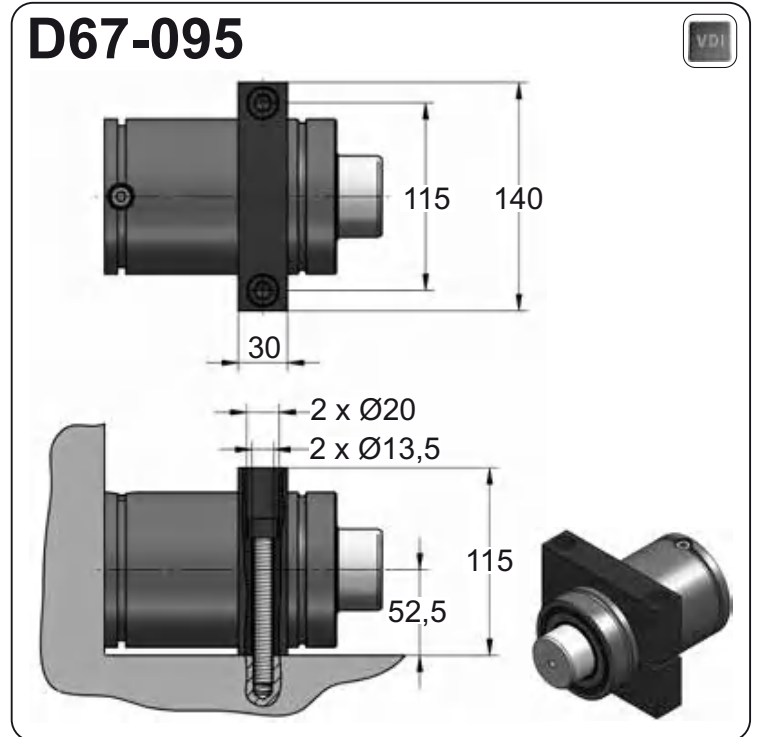

CODE	CW 4200 050 V1	KIT S-XXXXXXX KIT C-XXXXXXX	D02-095	18 CG 1-Q
ENG ORDER	GAS SPRING	REPAIR KIT	FLANGE	CHARGING ADAPTER
DEU BESTELLUNG	GASDRUCKFEDER	ERSATZTEILSATZ	FLANSCHEN	LADEADAPTER
FRA COMMANDE	RESSORT À GAZ	KIT DE RÉPARATION	BRIDE	RACCORD DE CHARGE
ITA ORDINE	CILINDRO AD AZOTO	KIT DI MANUTENZIONE	FLANGE	ADATTATORE DI CARICO
ESP PEDIDO	RESORTE DE GAS	KIT DE REPARACION	BRIDA	ADAPTADOR DE CARGA
POR PEDIDO	CILINDRO DE GÁS	KIT DE MANUTENÇÃO	FLANGE	ADAPTADOR DE CARGA

# CW 6600

Compact Height

BMW B2 4005	FORD W-DX35-6204
MB B8 3180 220 000 004	GM 90.25.08
VW 39D 997	

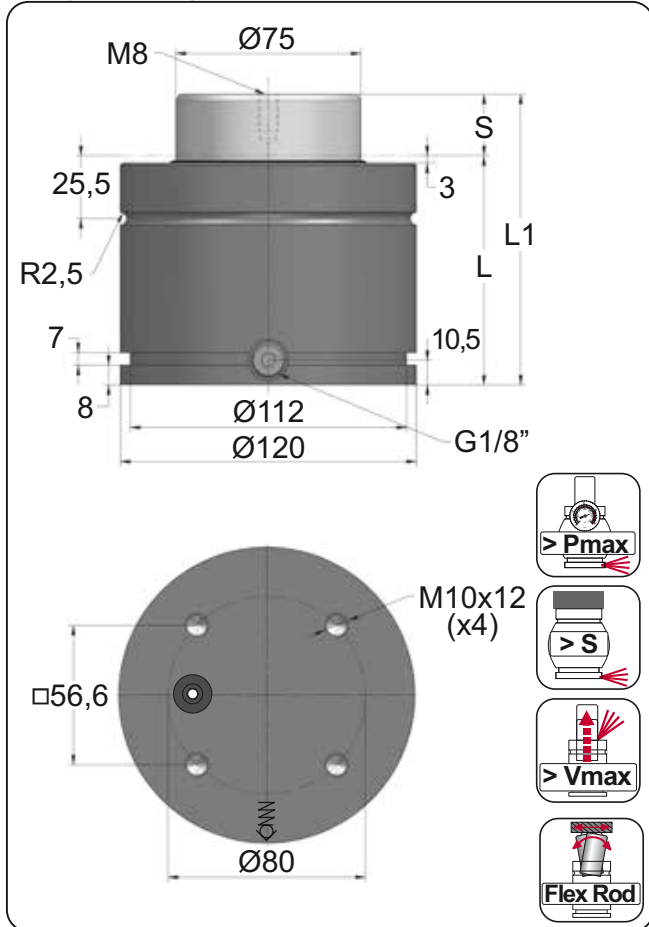

ORDER	S (mm)	L1 ±0.25 (mm)	L (mm)	Kg.
CW 6600 016	16	100	84	5.51
CW 6600 019	19	106	87	5.65
CW 6600 025	25	118	93	5.93
CW 6600 032	32	132	100	6.26
CW 6600 038	38	144	106	6.53
CW 6600 050	50	168	118	7.09
CW 6600 063	63	194	131	7.69
CW 6600 075	75	218	143	8.25
CW 6600 080	80	228	148	8.48
CW 6600 100	100	268	168	9.41
CW 6600 125	125	318	193	10.57



CODE	Image	bar	psi	F <sub>0</sub> daN	F <sub>1</sub> daN
CW 6600 050		150	2175	6630	10810
CW-H 6600 050		0	0	---	---

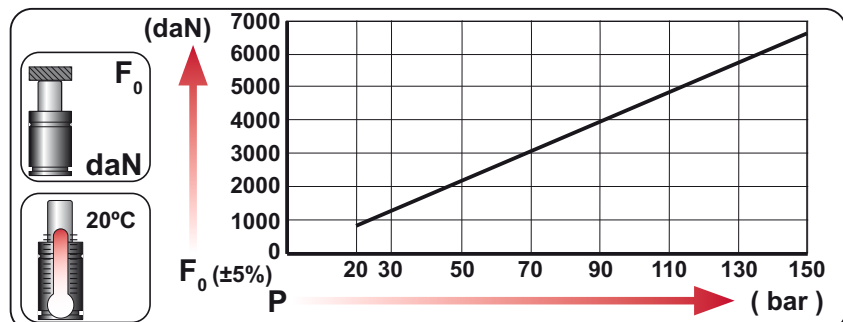

**EQUIPPED WITH VDI - SAFETY**

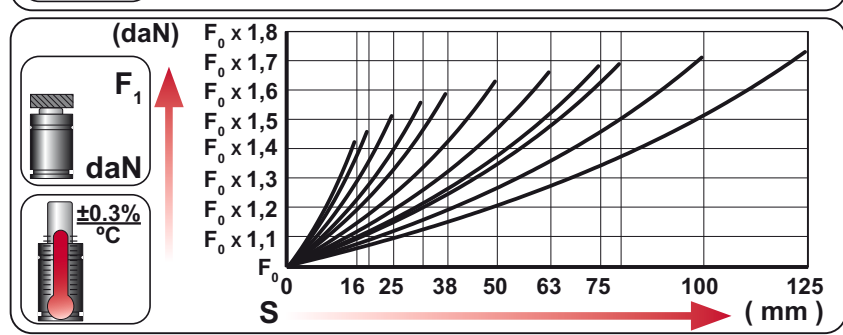

	ENG ORDER		
	DEU BESTELLUNG		
	FRA COMMANDE		
	ITA ORDINE		
	ESP PEDIDO		
POR PEDIDO			
<b>CW 6600 050</b>	<b>6600</b>	<b>50</b>	

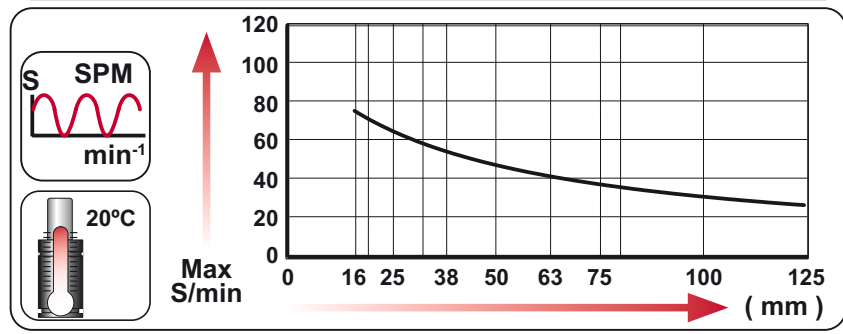

N <sub>2</sub>	S <sub>max</sub> < 90%	V <sub>max</sub> 1,6 m/s	bar psi	bar psi	°C °F	°C °F	600 CP-

N <sub>2</sub>	S <sub>max</sub> < 90%	V <sub>max</sub> 1,6 m/s	bar psi	bar psi	°C °F	°C °F	600 CP-
			20 290	150 2175	0 32	80 176	



# CW 6600 MOUNTS

Compact Height

		50		50	50	50		50
		Ø120		Ø120	Ø120	Ø120		Ø120
		L1=168 L1=172 L1=172		L1=190	L1=202 L1=215 L1=240	L1=240		L1=260
MODEL	X	CW 6600 KZ 6600 KT 6600	X	FD 5000	GN 5000 CM 6500 CD 6600	AG 5000	X	CS 11800
SERIES	MINI	COMPACT HEIGHT	THREADED	LOW PROFILE	HEAVY DUTY	ISO	HEAVY LOAD	POWER COMPACT STROKE

## A14-120

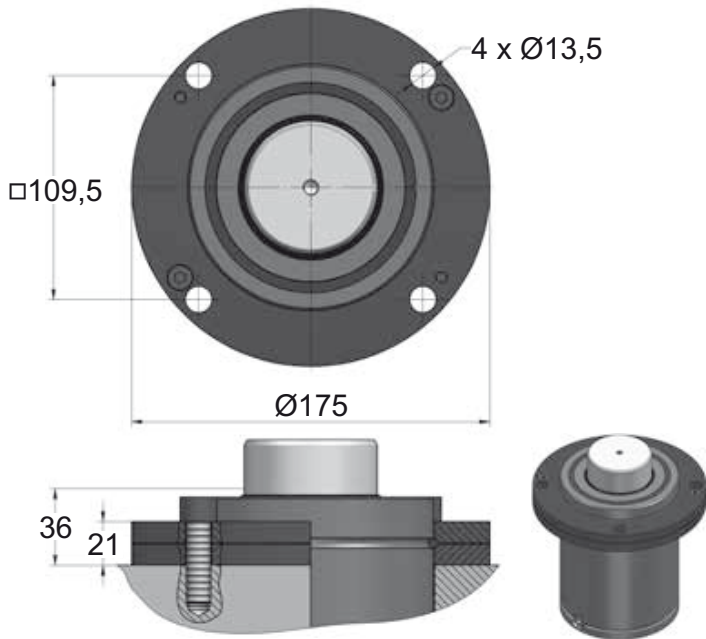

## A34-120

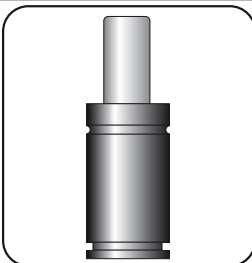
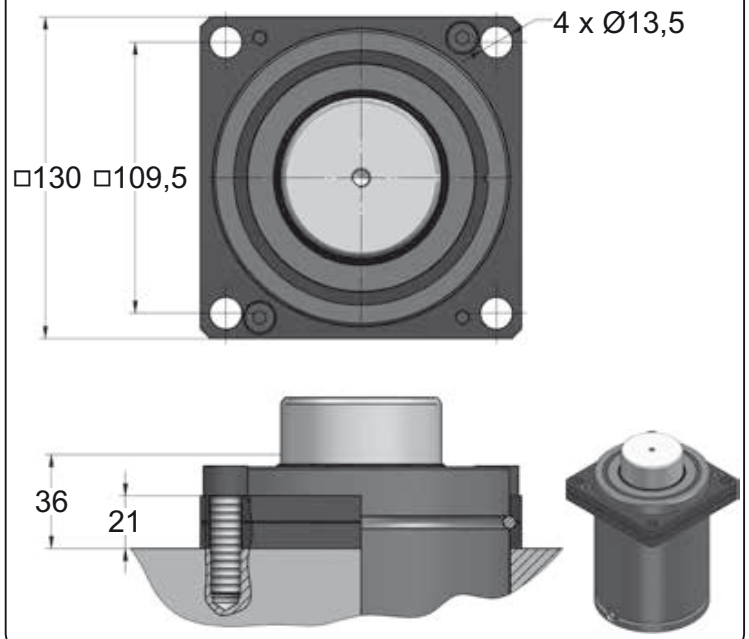

SEAL KIT S-XXXXXXX

CARTRIDGE KIT C-XXXXXXX

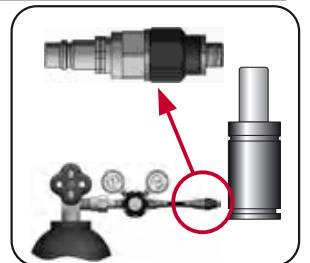
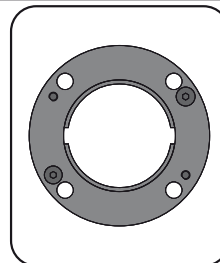

CODE	CW 6600 050	KIT S-XXXXXXX KIT C-XXXXXXX	A14-120	18 CG 1-Q
ENG ORDER	GAS SPRING	REPAIR KIT	FLANGE	CHARGING ADAPTER
DEU BESTELLUNG	GASDRUCKFEDER	ERSATZTEILSATZ	FLANSCH	LADEADAPTER
FRA COMMANDE	RESSORT À GAZ	KIT DE RÉPARATION	BRIDE	RACCORD DE CHARGE
ITA ORDINE	CILINDRO AD AZOTO	KIT DI MANUTENZIONE	FLANGE	ADATTATORE DI CARICO
ESP PEDIDO	RESORTE DE GAS	KIT DE REPARACION	BRIDA	ADAPTADOR DE CARGA
POR PEDIDO	CILINDRO DE GÁS	KIT DE MANUTENÇÃO	FLANGE	ADAPTADOR DE CARGA

# CW 6600 MOUNTS

Compact Height



### B36-120

### B41-120

### C05-120

### C20-120

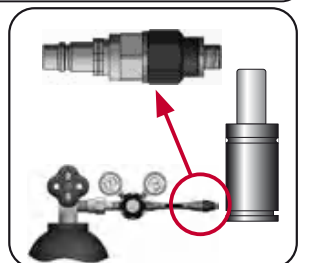
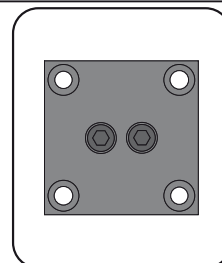
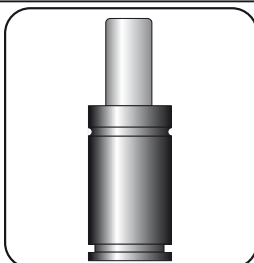
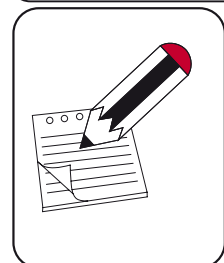

CODE	CW 6600 050	KIT S-XXXXXXX KIT C-XXXXXXX	B36-120	18 CG 1-Q
ENG	ORDER	GAS SPRING	REPAIR KIT	CHARGING ADAPTER
DEU	BESTELLUNG	GASDRUCKFEDER	ERSATZTEILSATZ	LADEADAPTER
FRA	COMMANDE	RESSORT À GAZ	KIT DE RÉPARATION	RACCORD DE CHARGE
ITA	ORDINE	CILINDRO AD AZOTO	KIT DI MANUTENZIONE	ADATTATORE DI CARICO
ESP	PEDIDO	RESORTE DE GAS	KIT DE REPARACION	ADAPTADOR DE CARGA
POR	PEDIDO	CILINDRO DE GÁS	KIT DE MANUTENÇÃO	ADAPTADOR DE CARGA





# CW 6600 MOUNTS

Compact Height

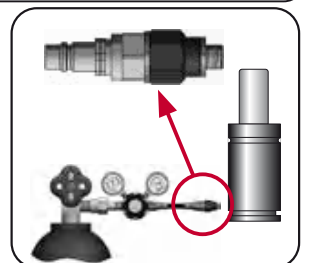
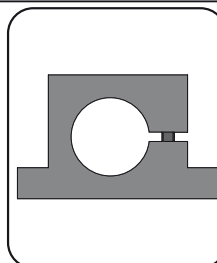
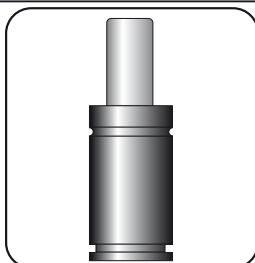
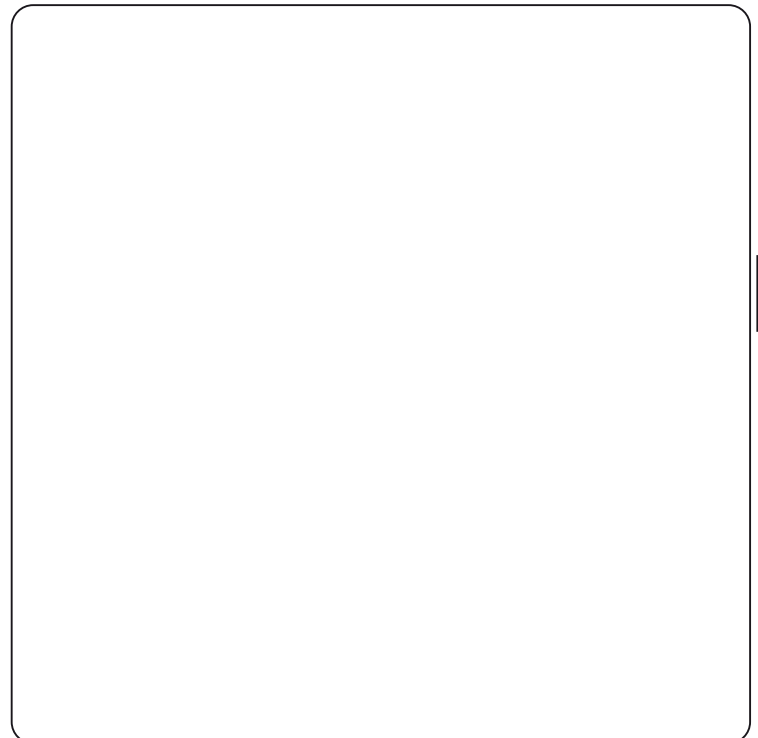
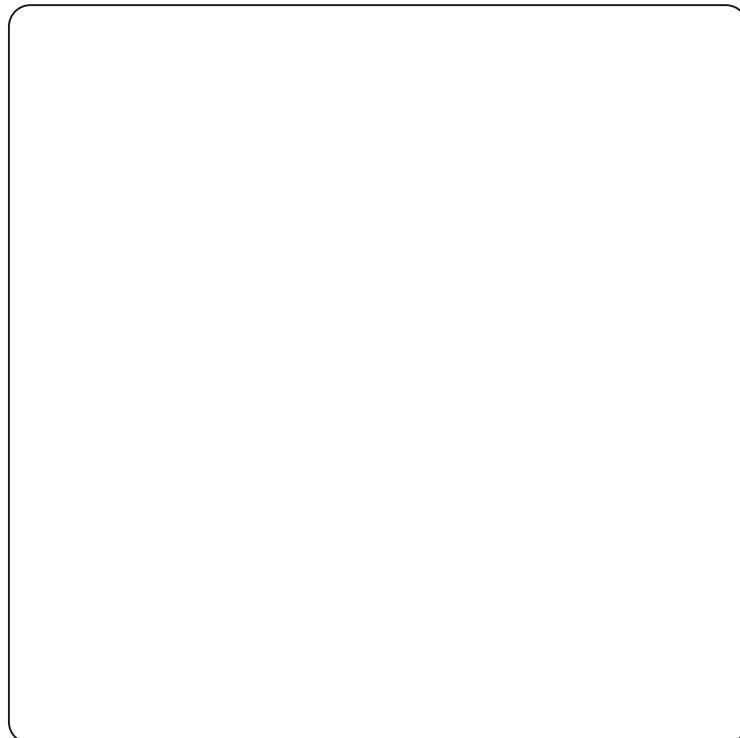
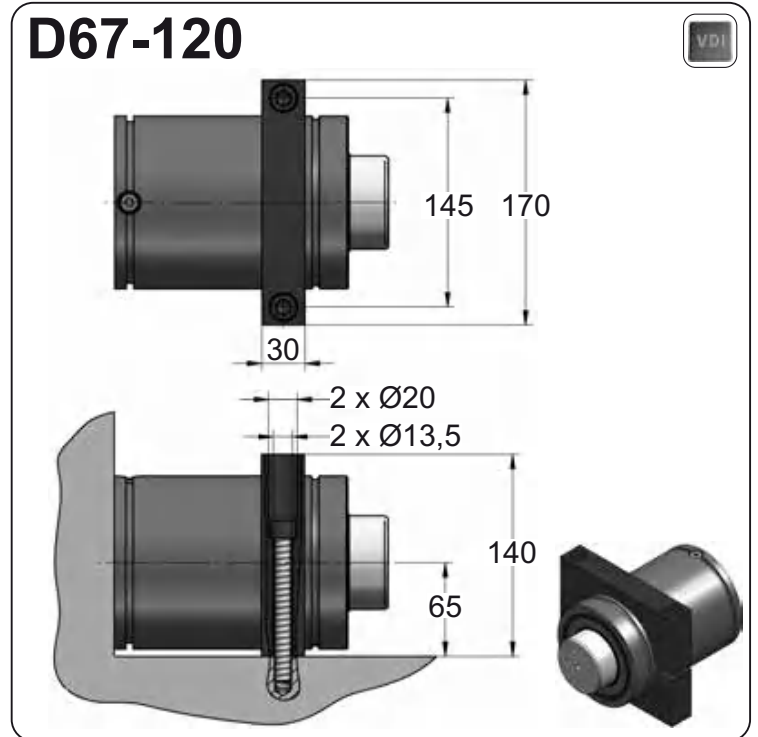

CODE	CW 6600 050	KIT S-XXXXXXX KIT C-XXXXXXX	D02-120	18 CG 1-Q
ENG	ORDER	GAS SPRING	REPAIR KIT	CHARGING ADAPTER
DEU	BESTELLUNG	GASDRUCKFEDER	ERSATZTEILSATZ	LADEADAPTER
FRA	COMMANDE	RESSORT À GAZ	KIT DE RÉPARATION	RACCORD DE CHARGE
ITA	ORDINE	CILINDRO AD AZOTO	KIT DI MANUTENZIONE	ADATTATORE DI CARICO
ESP	PEDIDO	RESORTE DE GAS	KIT DE REPARACION	ADAPTADOR DE CARGA
POR	PEDIDO	CILINDRO DE GÁS	KIT DE MANUTENÇÃO	ADAPTADOR DE CARGA

# CW 9500

Compact Height

BMW B2 4005	FORD W-DX35-6204
MB B8 3180 220 000 004	GM 90.25.08
VW 39D 997	

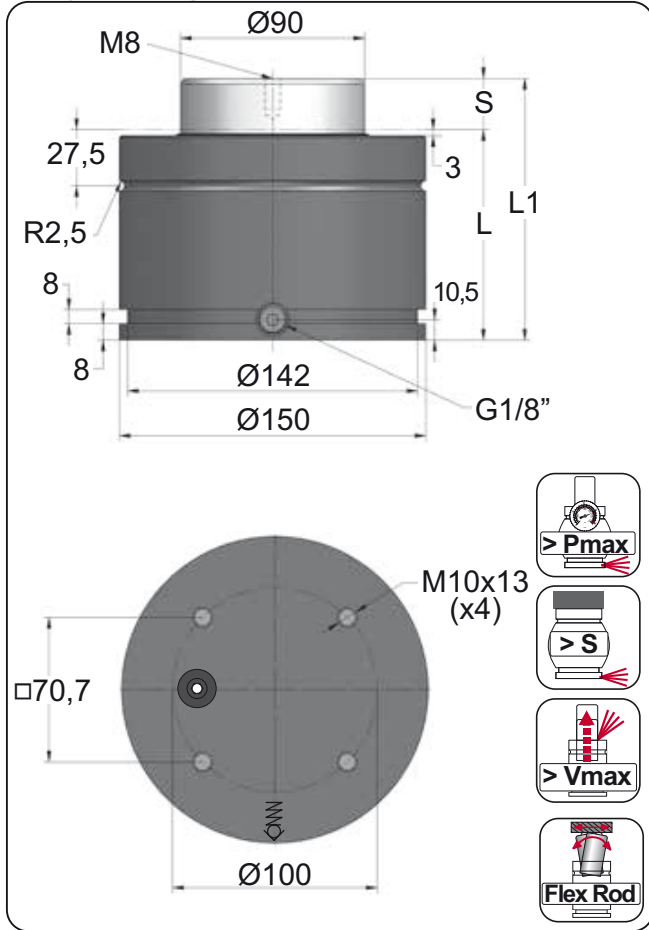

ORDER	S (mm)	L1 ±0.25 (mm)	L (mm)	Kg.
CW 9500 019	19	116	97	9.96
CW 9500 025	25	128	103	10.35
CW 9500 032	32	142	110	10.82
CW 9500 038	38	154	116	11.22
CW 9500 050	50	178	128	12.01
CW 9500 063	63	204	141	12.87
CW 9500 075	75	228	153	13.67
CW 9500 080	80	238	158	14.00
CW 9500 100	100	278	178	15.32
CW 9500 125	125	328	203	16.98



CODE	Pressure Gauge	bar	psi	F <sub>0</sub> daN	F <sub>1</sub> daN
CW 9500 050		150	2175	9540	14520
CW-H 9500 050		0	0	---	---

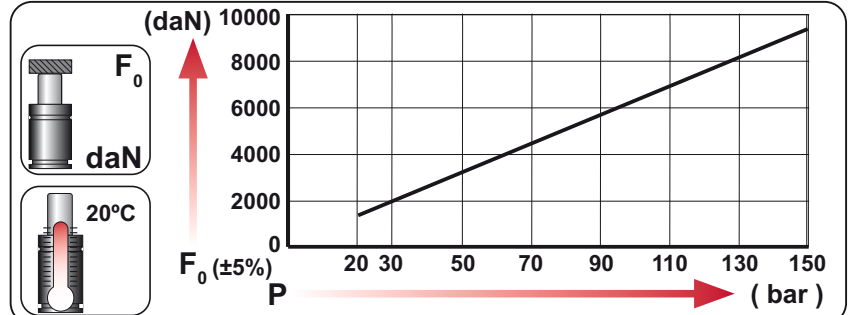

VDI 3003 **EQUIPPED WITH VDI - SAFETY**

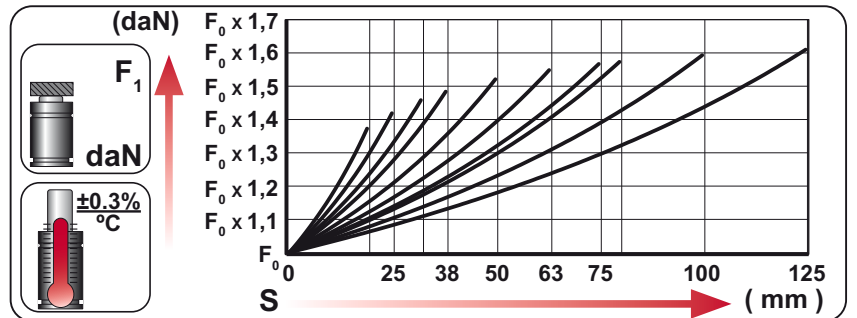

	ENG ORDER		F <sub>0</sub> daN		S mm
	DEU BESTELLUNG				
	FRA COMMANDE				
	ITA ORDINE				
	ESP PEDIDO				
	POR PEDIDO				
<b>CW 9500 050</b>		<b>9500</b>	<b>50</b>		

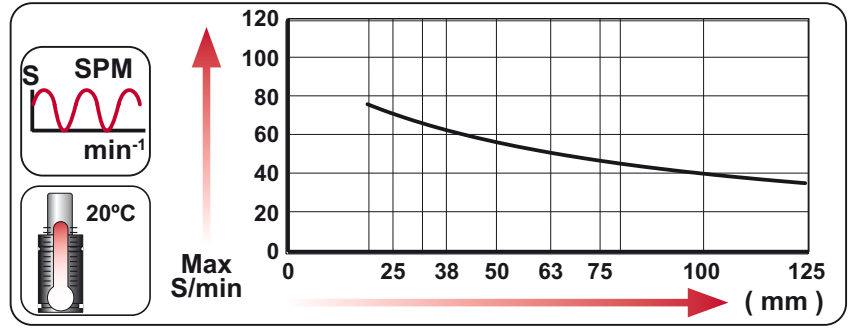

N <sub>2</sub>	S <sub>max</sub> < 90%	V <sub>max</sub> 1,6 m/s	bar psi	bar psi	°C °F	°C °F	600 CP-

N <sub>2</sub>	S <sub>max</sub> < 90%	V <sub>max</sub> 1,6 m/s	bar psi	bar psi	°C °F	°C °F	600 CP-
			20 290	150 2175	0 32	80 176	



# CW 9500 MOUNTS

Compact Height

s mm Ø mm L1 mm		50 Ø150 L1=178 L1=178 L1=178			50 Ø150 L1=205 L1=236 L1=255	50 Ø150 L1=255		50 Ø150 L1=270
MODEL	X	CW 9500 CW 11800 KT 9500	X	X	GN 7500 CM 10000 CD 9600	AG 7500	X	CS 18300
SERIES	MINI 	COMPACT HEIGHT 	THREADED 	LOW PROFILE 	HEAVY DUTY 	ISO 	HEAVY LOAD 	POWER COMPACT STROKE 

## A14-150

ISO 5218  
E24.54.815.G  
EM24.54.700/F

4 x Ø17,5

Ø220

□138

41 27

## A34-150

ISO 5218 VDI

4 x Ø17,5

□162 □138

41 27

SEAL  
KIT S-XXXXXXX

CARTRIDGE  
KIT C-XXXXXXX

CODE	CW 9500 050	KIT S-XXXXXXX KIT C-XXXXXXX	A14-150	18 CG 1-Q
ENG	ORDER	GAS SPRING	FLANGE	CHARGING ADAPTER
DEU	BESTELLUNG	GASDRUCKFEDER	FLANSCH	LADEADAPTER
FRA	COMMANDE	RESSORT À GAZ	BRIDE	RACCORD DE CHARGE
ITA	ORDINE	CILINDRO AD AZOTO	FLANGE	ADATTATORE DI CARICO
ESP	PEDIDO	RESORTE DE GAS	BRIDA	ADAPTADOR DE CARGA
POR	PEDIDO	CILINDRO DE GÁS	FLANGE	ADAPTADOR DE CARGA

# CW 9500 MOUNTS

Compact Height

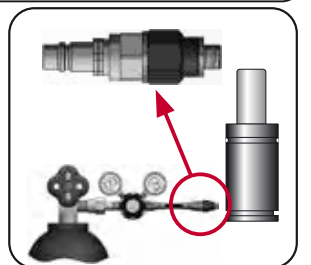
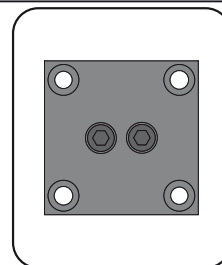
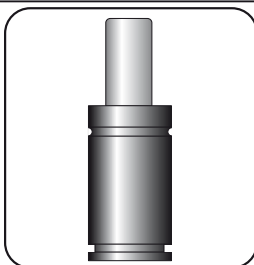
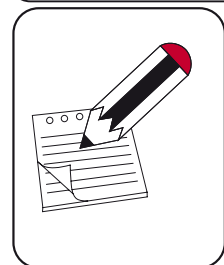
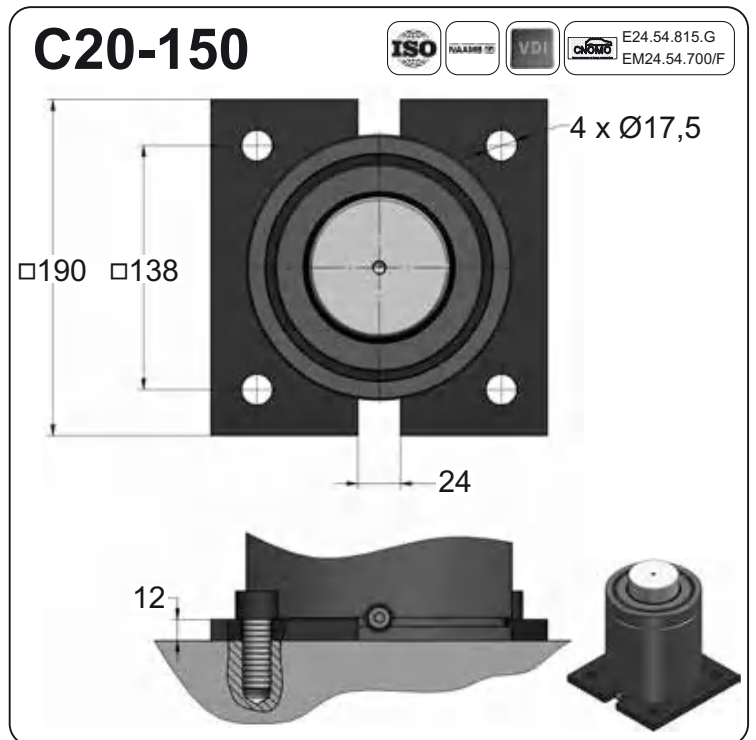
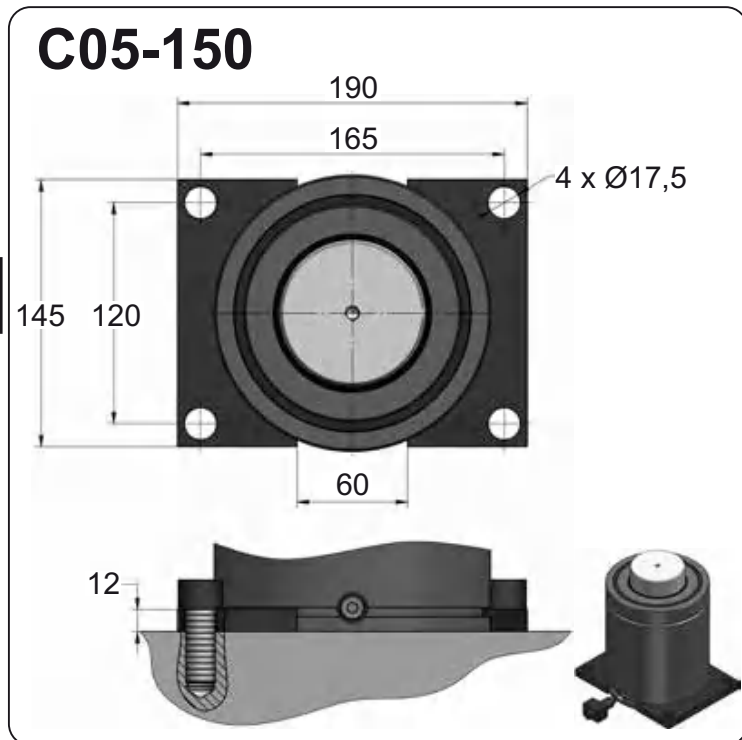
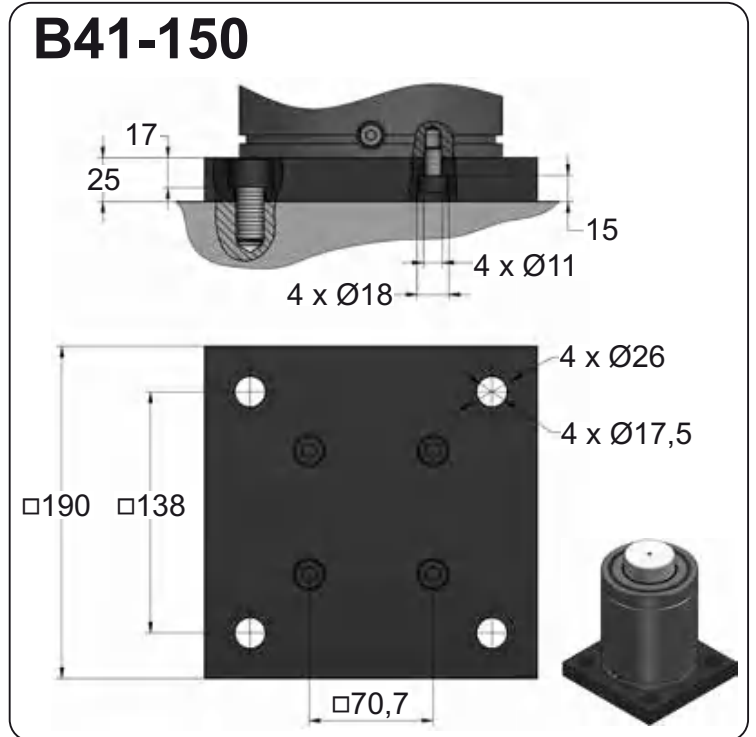
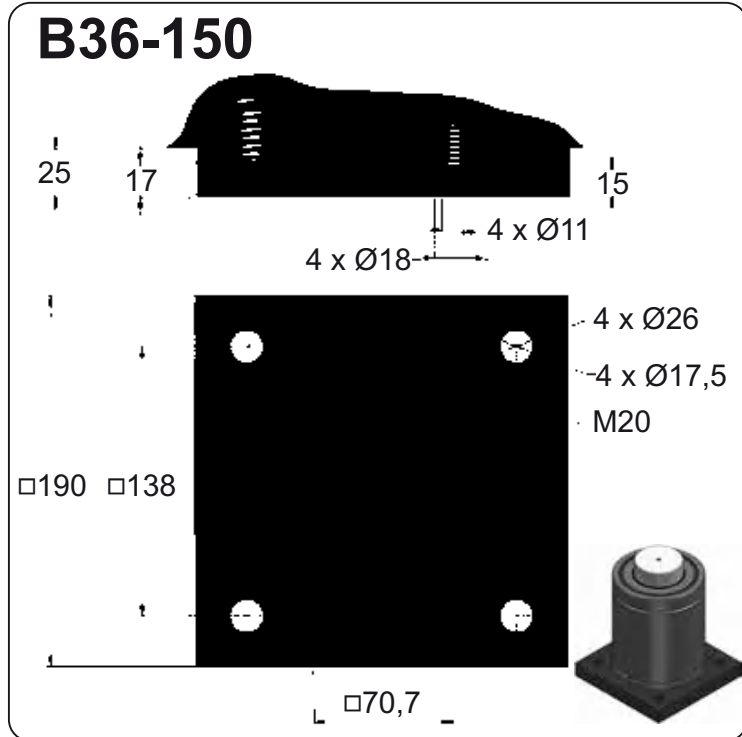

CODE	CW 9500 050	KIT S-XXXXXXX KIT C-XXXXXXX	B36-150	18 CG 1-Q
ENG ORDER	GAS SPRING	REPAIR KIT	FLANGE	CHARGING ADAPTER
DEU BESTELLUNG	GASDRUCKFEDER	ERSATZTEILSATZ	FLANSCH	LADEADAPTER
FRA COMMANDE	RESSORT À GAZ	KIT DE RÉPARATION	BRIDE	RACCORD DE CHARGE
ITA ORDINE	CILINDRO AD AZOTO	KIT DI MANUTENZIONE	FLANGE	ADATTATORE DI CARICO
ESP PEDIDO	RESORTE DE GAS	KIT DE REPARACION	BRIDA	ADAPTADOR DE CARGA
POR PEDIDO	CILINDRO DE GÁS	KIT DE MANUTENÇÃO	FLANGE	ADAPTADOR DE CARGA





# CW 9500 MOUNTS

Compact Height

## D02-150

2 x Ø13,5

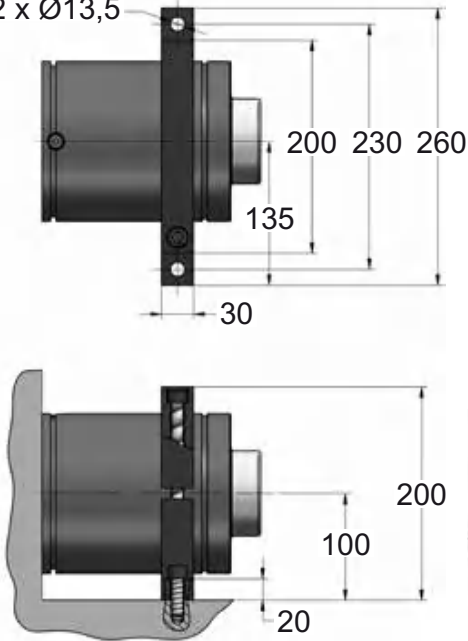

## D67-150

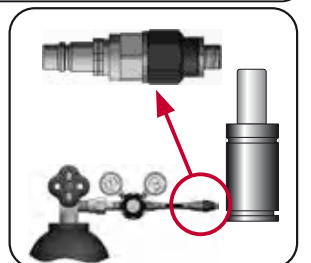
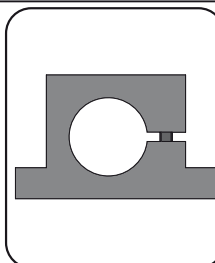
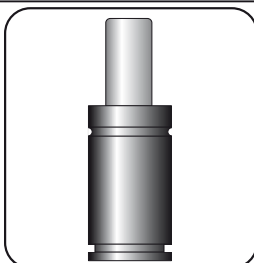
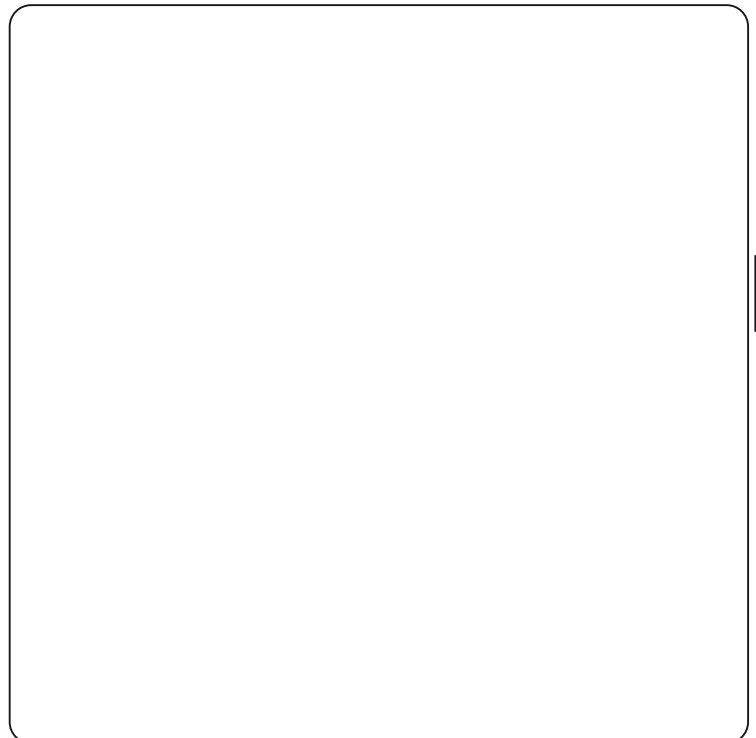
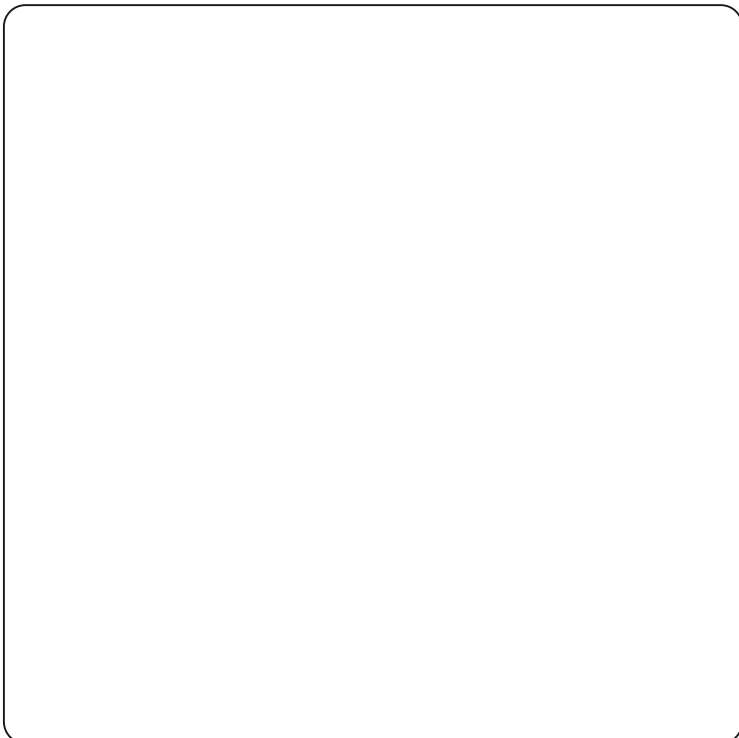
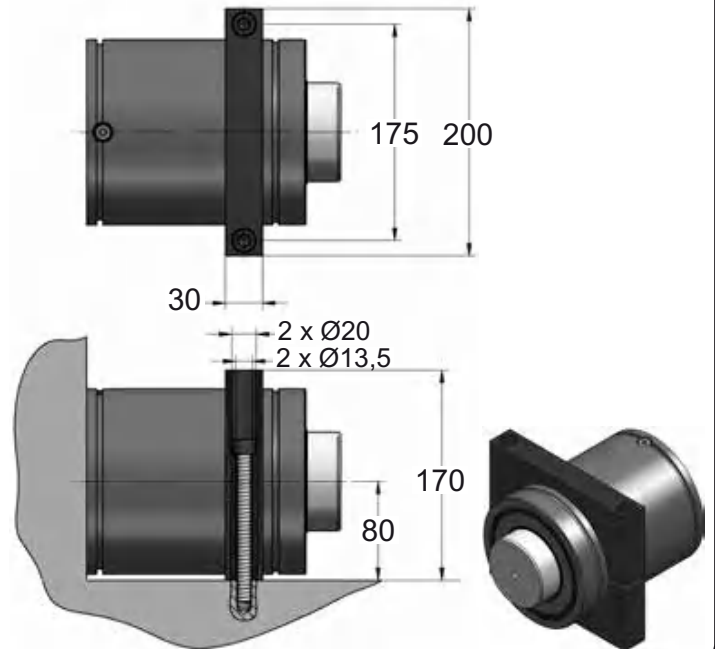

CODE	CW 9500 050	KIT S-XXXXXXX KIT C-XXXXXXX	D02-150	18 CG 1-Q
ENG	ORDER	GAS SPRING	REPAIR KIT	CHARGING ADAPTER
DEU	BESTELLUNG	GASDRUCKFEDER	ERSATZTEILSATZ	LADEADAPTER
FRA	COMMANDE	RESSORT À GAZ	KIT DE RÉPARATION	RACCORD DE CHARGE
ITA	ORDINE	CILINDRO AD AZOTO	KIT DI MANUTENZIONE	ADATTATORE DI CARICO
ESP	PEDIDO	RESORTE DE GAS	KIT DE REPARACION	ADAPTADOR DE CARGA
POR	PEDIDO	CILINDRO DE GÁS	KIT DE MANUTENÇÃO	ADAPTADOR DE CARGA

# CW 11800

Compact Height

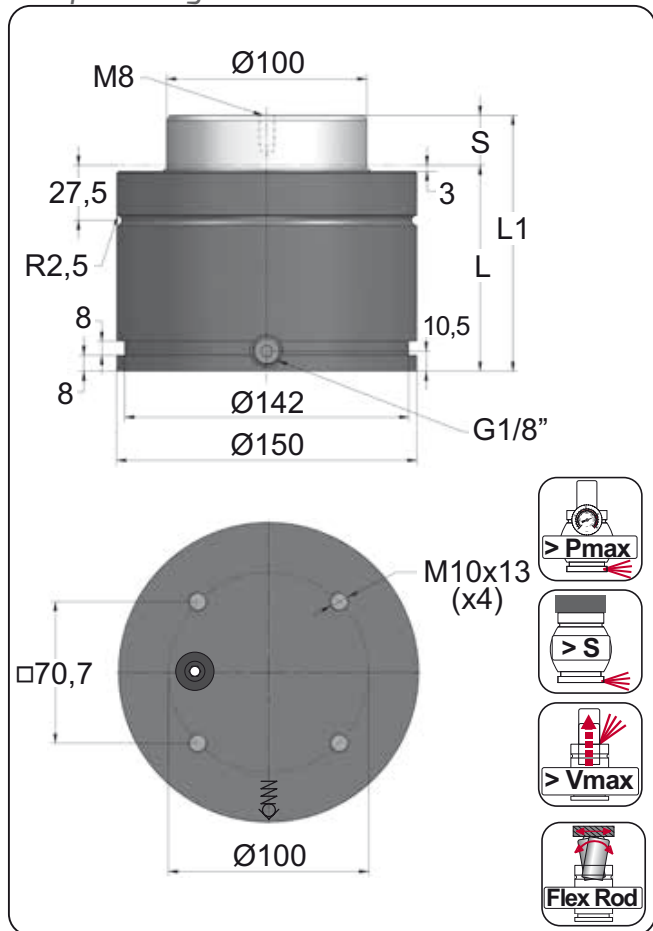

ORDER	S (mm)	L1 ±0.25 (mm)	L (mm)	Kg.
CW 11800 019	19	116	97	9.89
CW 11800 025	25	128	103	10.31
CW 11800 032	32	142	110	10.79
CW 11800 038	38	154	116	11.21
CW 11800 050	50	178	128	12.04
CW 11800 063	63	204	141	12.94
CW 11800 075	75	228	153	13.78
CW 11800 080	80	238	158	14.12
CW 11800 100	100	278	178	15.51
CW 11800 125	125	328	203	17.25



CODE	Image	Pressure		Force	
		bar	psi	daN	daN
CW 11800 050		150	2175	11780	19265
CW-H 11800 050		0	0	---	---

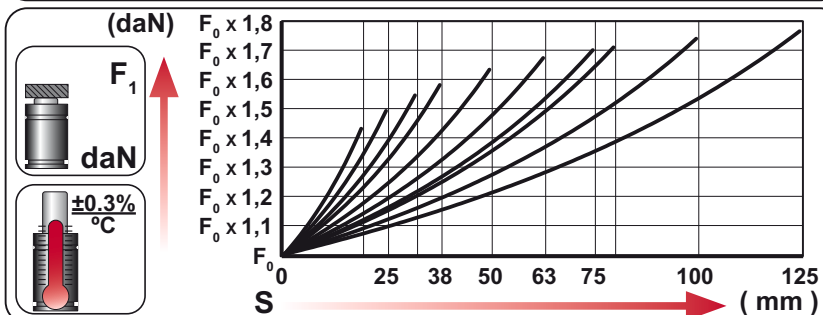
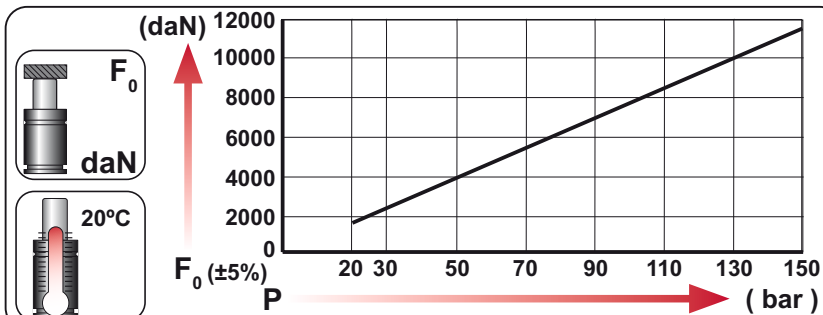

**EQUIPPED WITH VDI - SAFETY**

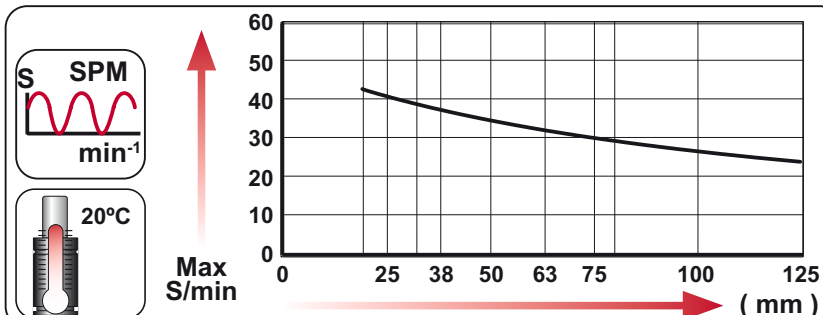

Language	Ordering Term	Force		Stroke	
		daN	mm	mm	mm
ENG	ORDER	11800	50		
DEU	BESTELLUNG				
FRA	COMMANDE				
ITA	ORDINE				
ESP	PEDIDO				
POR	PEDIDO				

--	--	--	--	--	--	--	--

N <sub>2</sub>	Smax < 90%	Vmax 1,6 m/s	bar psi	bar psi	°C °F	°C °F	600 CP-
			20 290	150 2175	0 32	80 176	



# CW 11800 MOUNTS

Compact Height

s mm Ø mm L1 mm		50 Ø150 L1=178 L1=178 L1=178			50 Ø150 L1=205 L1=236 L1=255	50 Ø150 L1=255		50 Ø150 L1=270
MODEL	X	CW 9500 CW 11800 KT 9500	X	X	GN 7500 CM 10000 CD 9600	AG 7500	X	CS 18300
SERIES	MINI 	COMPACT HEIGHT 	THREADED 	LOW PROFILE 	HEAVY DUTY 	ISO 	HEAVY LOAD 	POWER COMPACT STROKE 

## A14-150

ISO 5207

ISO 5207

E24.54.815.G  
EM24.54.700/F

4 x Ø17,5

□138

Ø220

41 27

## A34-150

ISO 5207

VDI

4 x Ø17,5

□162 □138

41 27

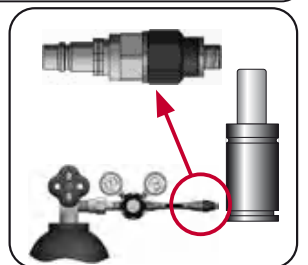
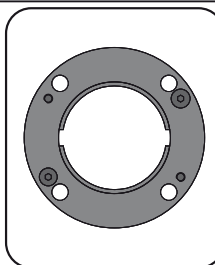
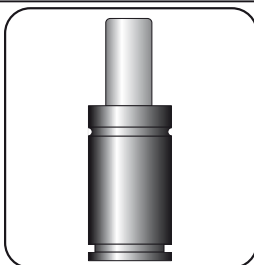

CODE	CW 11800 050	KIT S-XXXXXXX KIT C-XXXXXXX	A14-150	18 CG 1-Q
ENG ORDER	GAS SPRING	REPAIR KIT	FLANGE	CHARGING ADAPTER
DEU BESTELLUNG	GASDRUCKFEDER	ERSATZTEILSATZ	FLANSCHEN	LADEADAPTER
FRA COMMANDE	RESSORT À GAZ	KIT DE RÉPARATION	BRIDE	RACCORD DE CHARGE
ITA ORDINE	CILINDRO AD AZOTO	KIT DI MANUTENZIONE	FLANGE	ADATTATORE DI CARICO
ESP PEDIDO	RESORTE DE GAS	KIT DE REPARACION	BRIDA	ADAPTADOR DE CARGA
POR PEDIDO	CILINDRO DE GÁS	KIT DE MANUTENÇÃO	FLANGE	ADAPTADOR DE CARGA

# CW 11800 MOUNTS

Compact Height

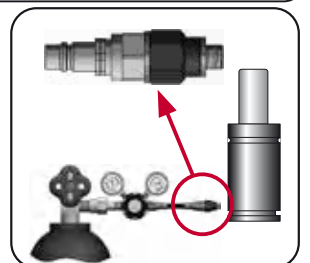
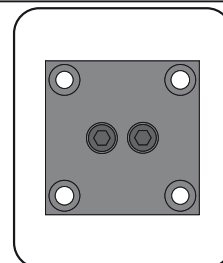
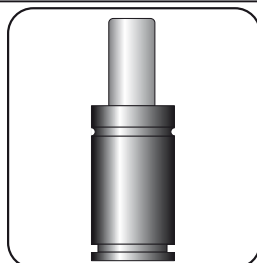
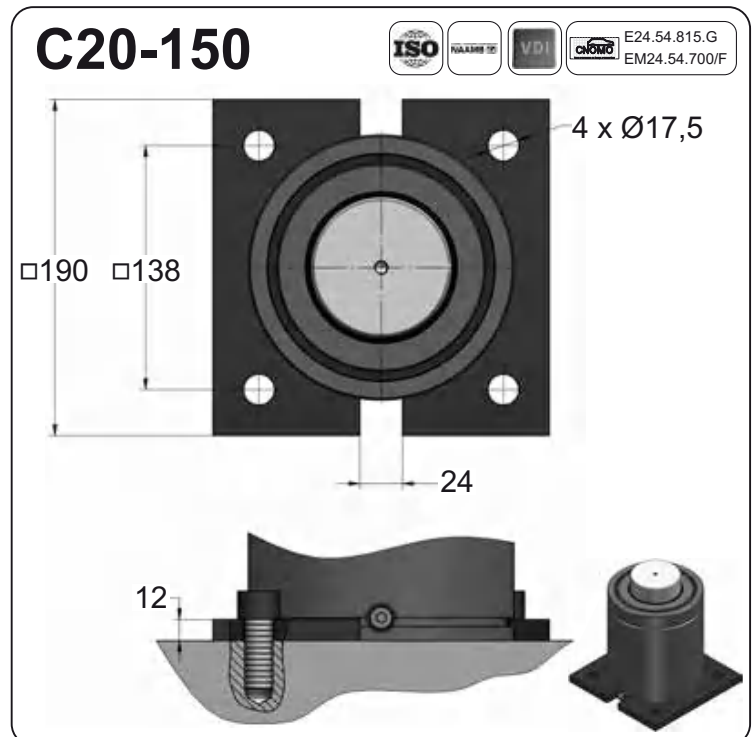
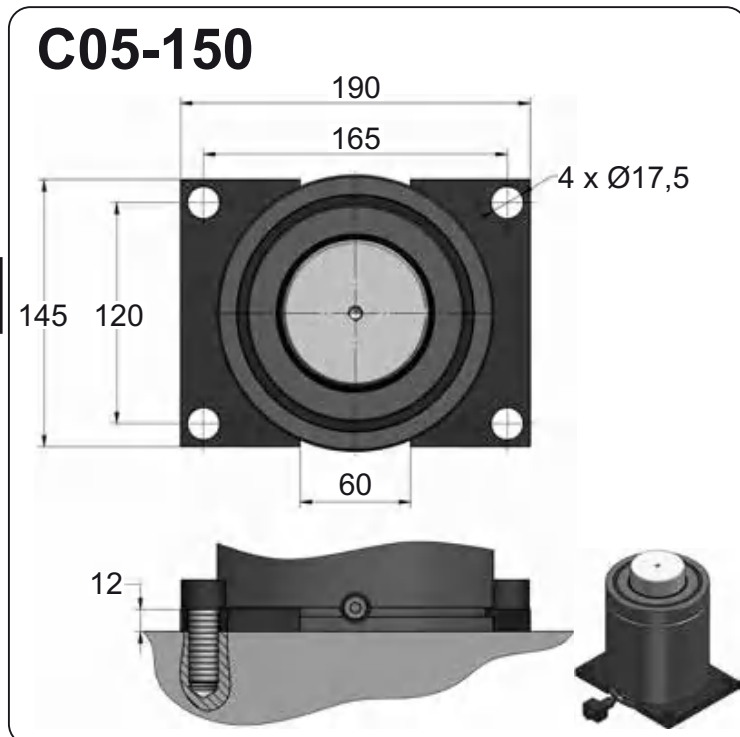
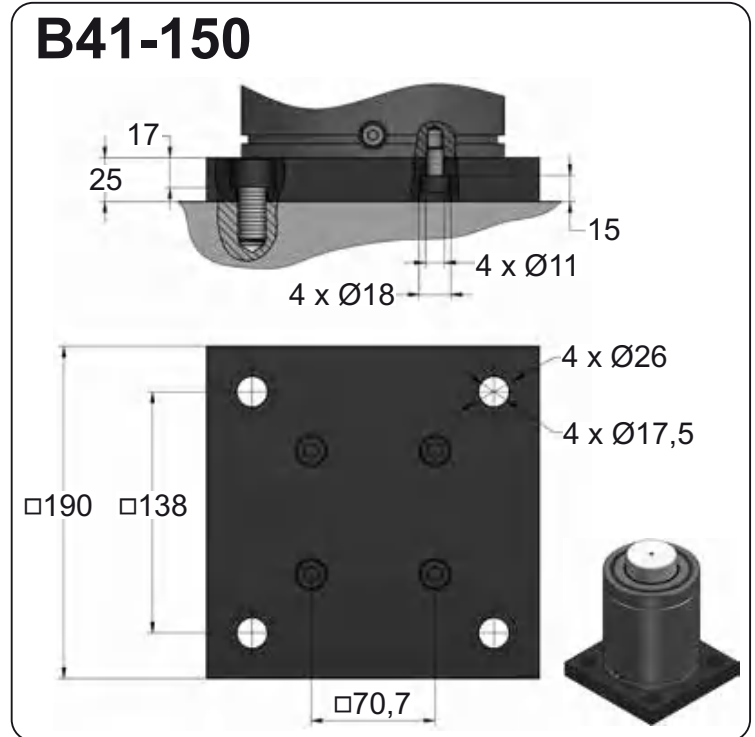
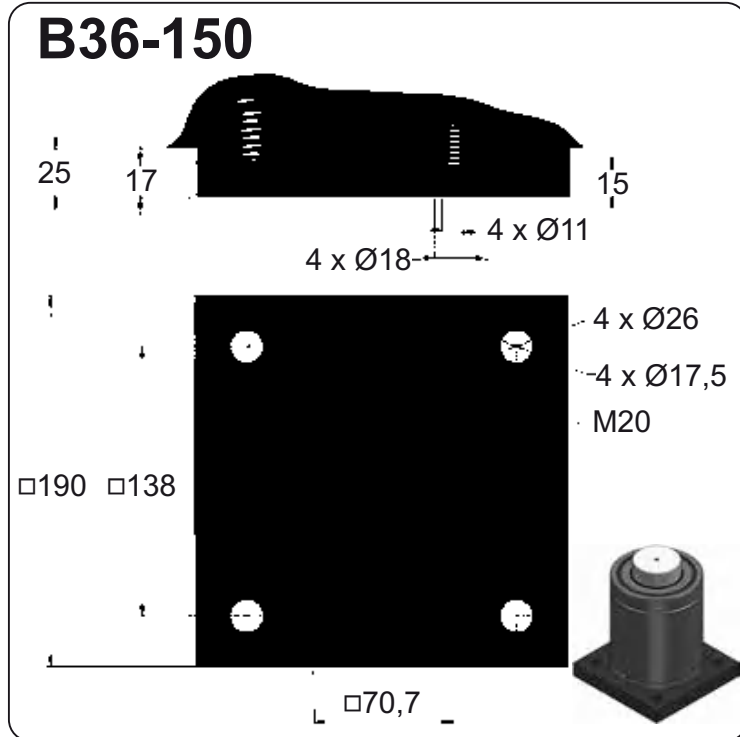

CODE	CW 11800 050	KIT S-XXXXXXX KIT C-XXXXXXX	B36-150	18 CG 1-Q
ENG ORDER	GAS SPRING	REPAIR KIT	FLANGE	CHARGING ADAPTER
DEU BESTELLUNG	GASDRUCKFEDER	ERSATZTEILSATZ	FLANSCH	LADEADAPTER
FRA COMMANDE	RESSORT À GAZ	KIT DE RÉPARATION	BRIDE	RACCORD DE CHARGE
ITA ORDINE	CILINDRO AD AZOTO	KIT DI MANUTENZIONE	FLANGE	ADATTATORE DI CARICO
ESP PEDIDO	RESORTE DE GAS	KIT DE REPARACION	BRIDA	ADAPTADOR DE CARGA
POR PEDIDO	CILINDRO DE GÁS	KIT DE MANUTENÇÃO	FLANGE	ADAPTADOR DE CARGA





# CW 11800 MOUNTS

Compact Height

## D02-150

2 x Ø13,5

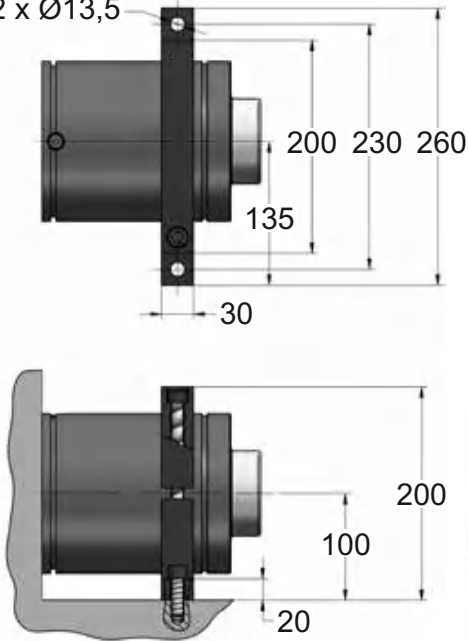

## D67-150

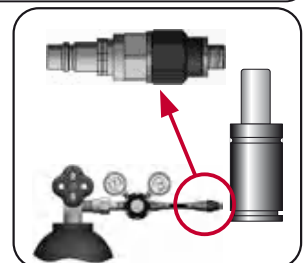
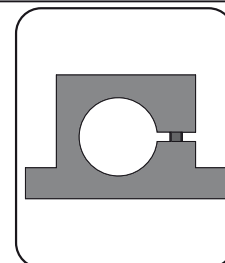
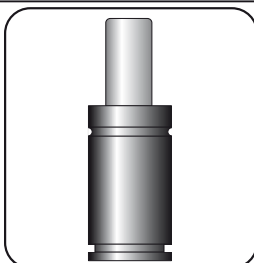
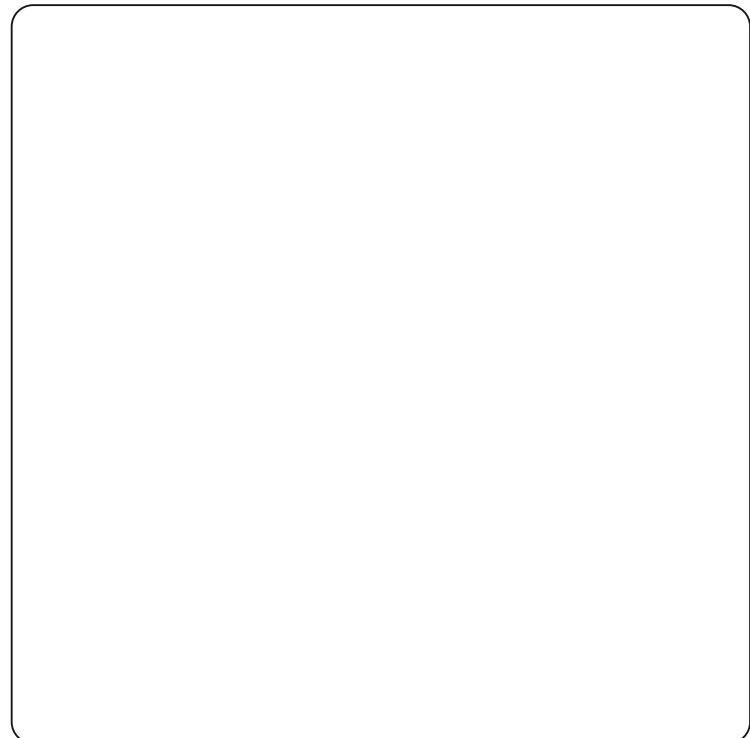
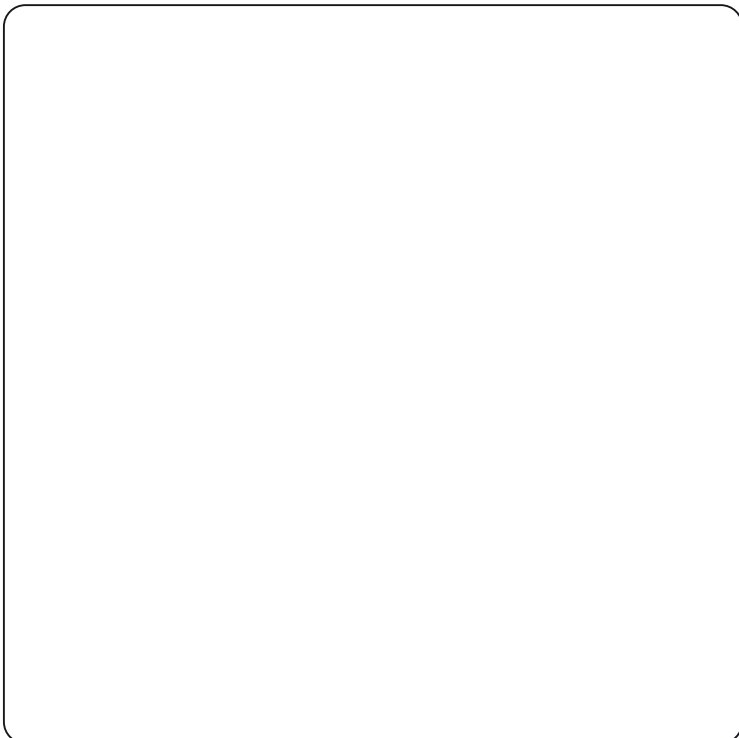
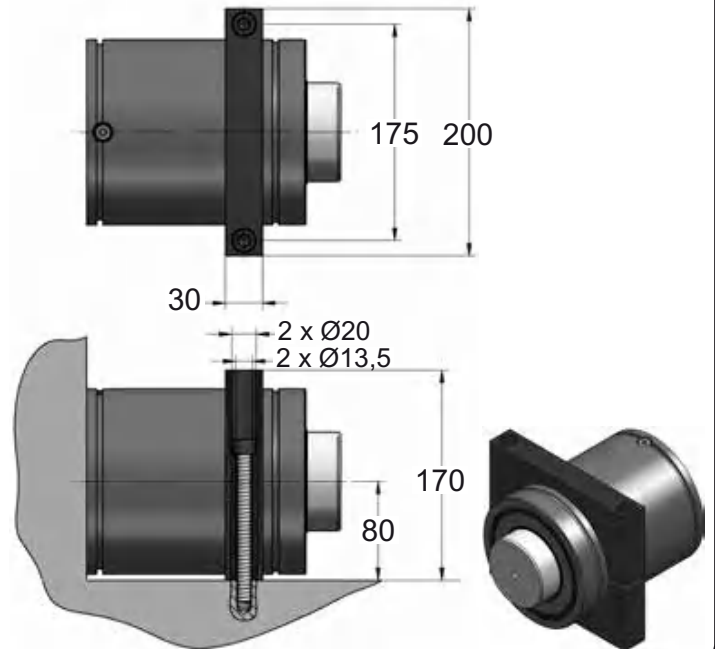

CODE	CW 11800 050	KIT S-XXXXXXX KIT C-XXXXXXX	D02-150	18 CG 1-Q
ENG	ORDER	GAS SPRING	REPAIR KIT	CHARGING ADAPTER
DEU	BESTELLUNG	GASDRUCKFEDER	ERSATZTEILSATZ	LADEADAPTER
FRA	COMMANDE	RESSORT À GAZ	KIT DE RÉPARATION	RACCORD DE CHARGE
ITA	ORDINE	CILINDRO AD AZOTO	KIT DI MANUTENZIONE	ADATTATORE DI CARICO
ESP	PEDIDO	RESORTE DE GAS	KIT DE REPARACION	ADAPTADOR DE CARGA
POR	PEDIDO	CILINDRO DE GÁS	KIT DE MANUTENÇÃO	ADAPTADOR DE CARGA

# CW 20000

Compact Height

	GM	90.25.08
--	----	----------

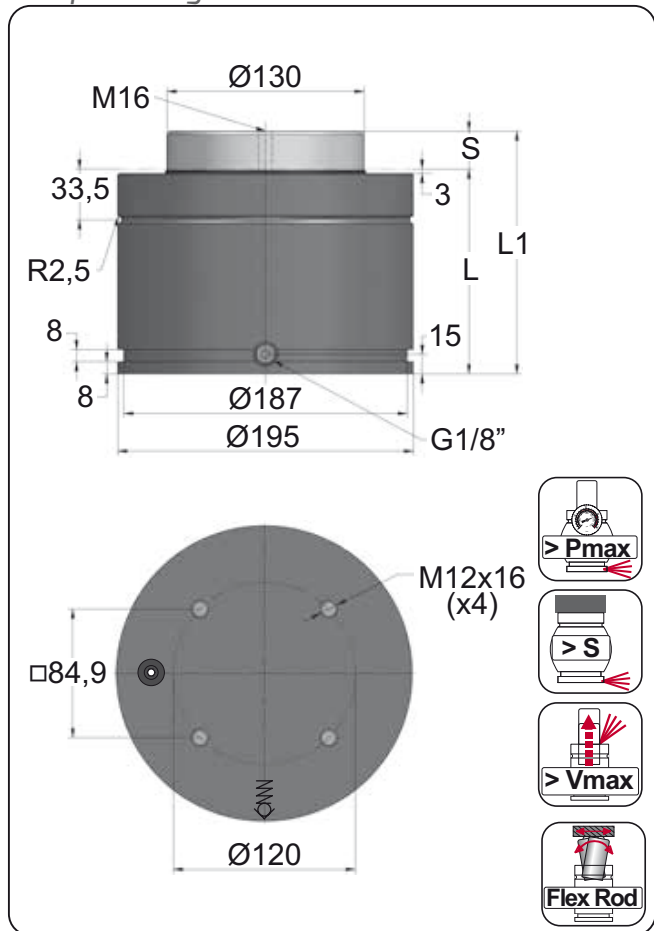

ORDER	S (mm)	L1 ±0.25 (mm)	L (mm)	Kg.
CW 20000 019	19	148	129	22.69
CW 20000 025	25	160	135	23.40
CW 20000 032	32	174	142	24.24
CW 20000 038	38	186	148	24.95
CW 20000 050	50	210	160	26.38
CW 20000 063	63	236	173	27.93
CW 20000 075	75	260	185	29.36
CW 20000 080	80	270	190	29.96
CW 20000 100	100	310	210	32.34
CW 20000 125	125	360	235	35.32

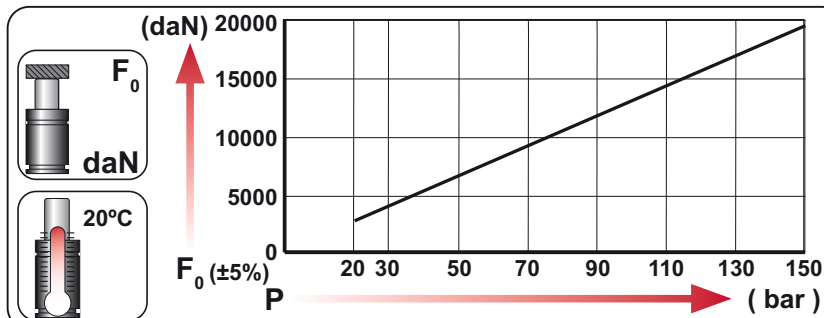

CODE	Image	Pressure		Force	
		bar	psi	daN	daN
CW 20000 050		150	2175	19910	31410
CW-H 20000 050		0	0	---	---

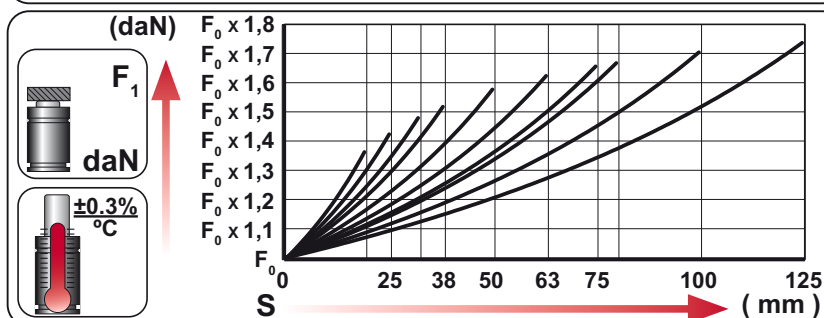

**EQUIPPED WITH VDI - SAFETY**

Language	Order	Force $F_0$ (daN)	Stroke $S$ (mm)
ENG	ORDER	20000	50
DEU	BESTELLUNG		
FRA	COMMANDE		
ITA	ORDINE		
ESP	PEDIDO		
POR	PEDIDO		

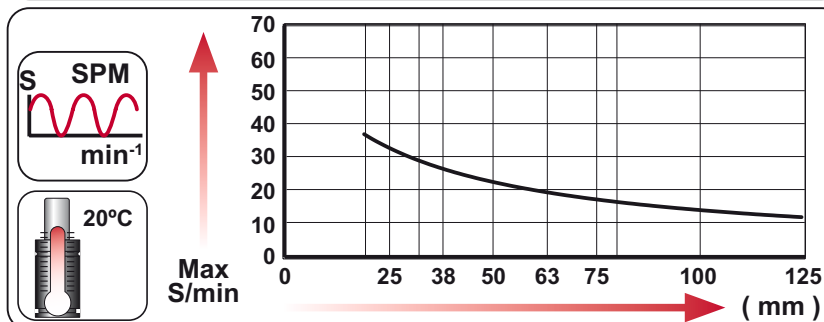

**CW 20000 050**      **20000**      **50**

--	--	--	--	--	--	--	--

N <sub>2</sub>	Smax < 90%	Vmax 1,6 m/s	bar psi	bar psi	°C °F	°C °F	600 CP-
			20 290	150 2175	0 32	80 176	



# CW 20000 MOUNTS

Compact Height

MODEL	X	CW 20000	X	X	CD 18500	AG 10000	X	X
SERIES	MINI 	COMPACT HEIGHT 	THREADED 	LOW PROFILE 	HEAVY DUTY 	ISO 	HEAVY LOAD 	POWER COMPACT STROKE 

## A14-195

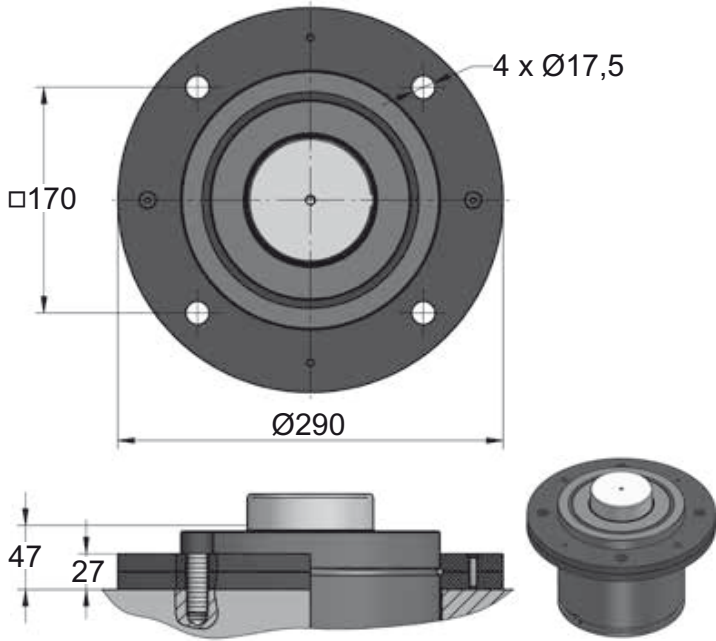

## A34-195

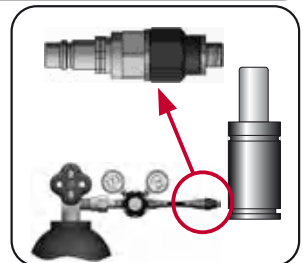
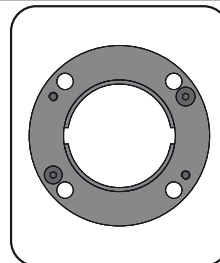
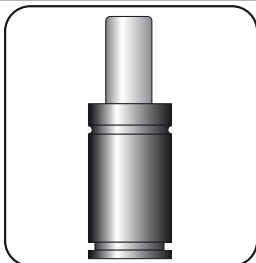
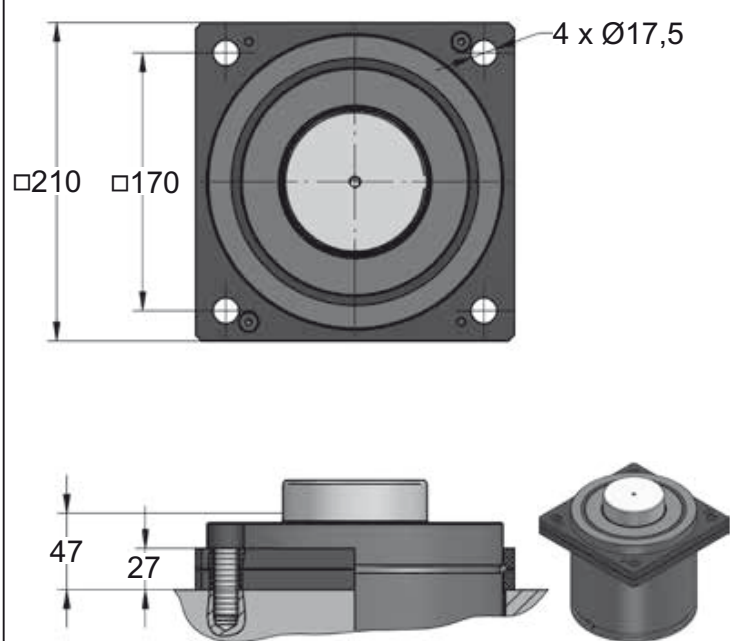

CODE	CW 20000 050	KIT S-XXXXXXX KIT C-XXXXXXX	A14-195	18 CG 1-Q
ENG ORDER	GAS SPRING	REPAIR KIT	FLANGE	CHARGING ADAPTER
DEU BESTELLUNG	GASDRUCKFEDER	ERSATZTEILSATZ	FLANSCH	LADEADAPTER
FRA COMMANDE	RESSORT À GAZ	KIT DE RÉPARATION	BRIDE	RACCORD DE CHARGE
ITA ORDINE	CILINDRO AD AZOTO	KIT DI MANUTENZIONE	FLANGE	ADATTATORE DI CARICO
ESP PEDIDO	RESORTE DE GAS	KIT DE REPARACION	BRIDA	ADAPTADOR DE CARGA
POR PEDIDO	CILINDRO DE GÁS	KIT DE MANUTENÇÃO	FLANGE	ADAPTADOR DE CARGA

# CW 20000 MOUNTS

Compact Height

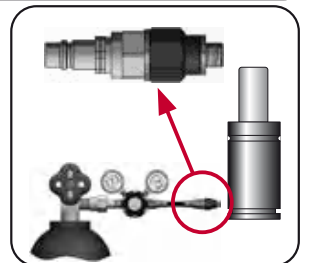
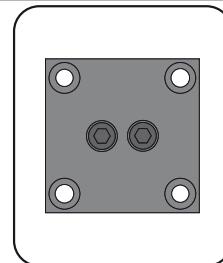
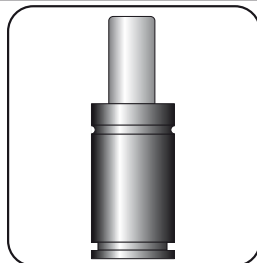
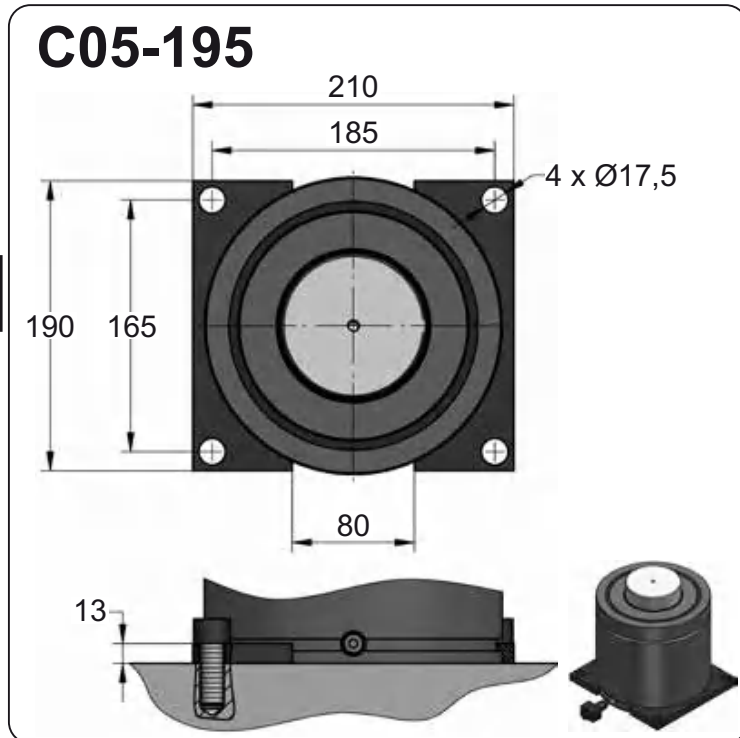
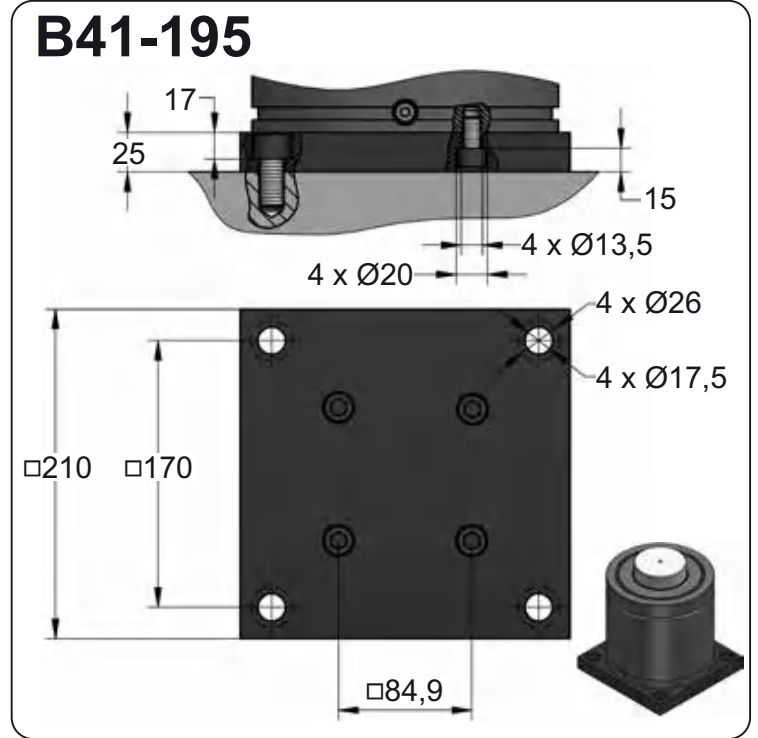
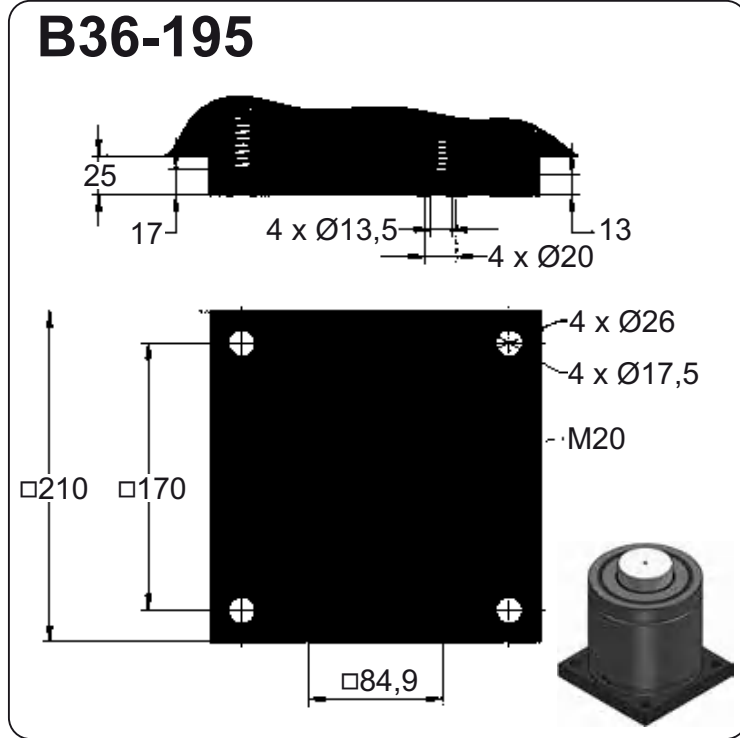

CODE	CW 20000 050	KIT S-XXXXXXX KIT C-XXXXXXX	B36-195	18 CG 1-Q
ENG ORDER	GAS SPRING	REPAIR KIT	FLANGE	CHARGING ADAPTER
DEU BESTELLUNG	GASDRUCKFEDER	ERSATZTEILSATZ	FLANSCHEN	LADEADAPTER
FRA COMMANDE	RESSORT À GAZ	KIT DE RÉPARATION	BRIDE	RACCORD DE CHARGE
ITA ORDINE	CILINDRO AD AZOTO	KIT DI MANUTENZIONE	FLANGE	ADATTATORE DI CARICO
ESP PEDIDO	RESORTE DE GAS	KIT DE REPARACION	BRIDA	ADAPTADOR DE CARGA
POR PEDIDO	CILINDRO DE GÁS	KIT DE MANUTENÇÃO	FLANGE	ADAPTADOR DE CARGA





# CW 20000 MOUNTS

Compact Height

## D02-195

2 x Ø13,5

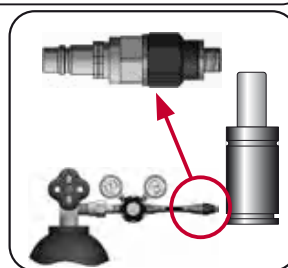
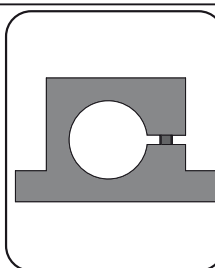
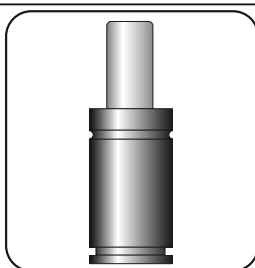
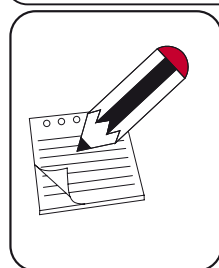
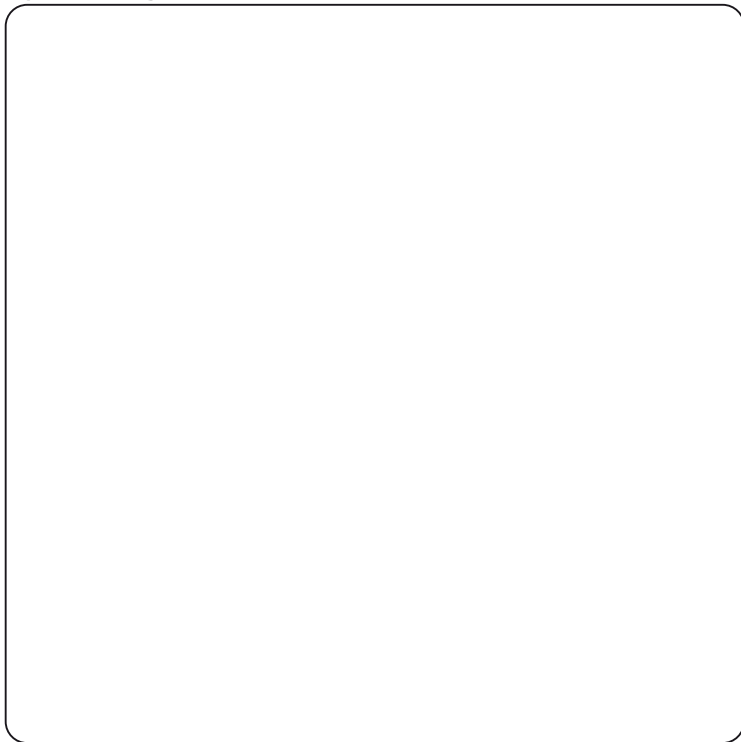
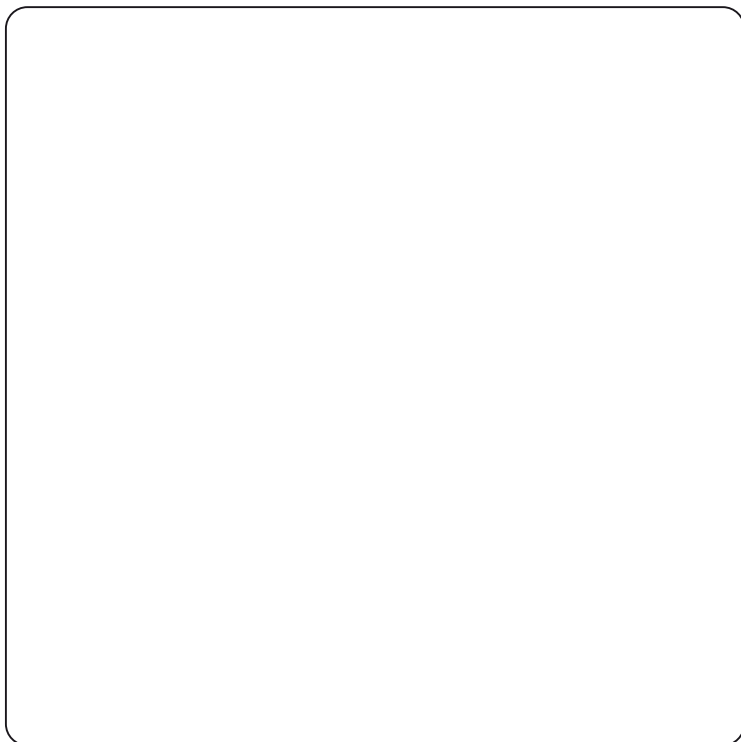
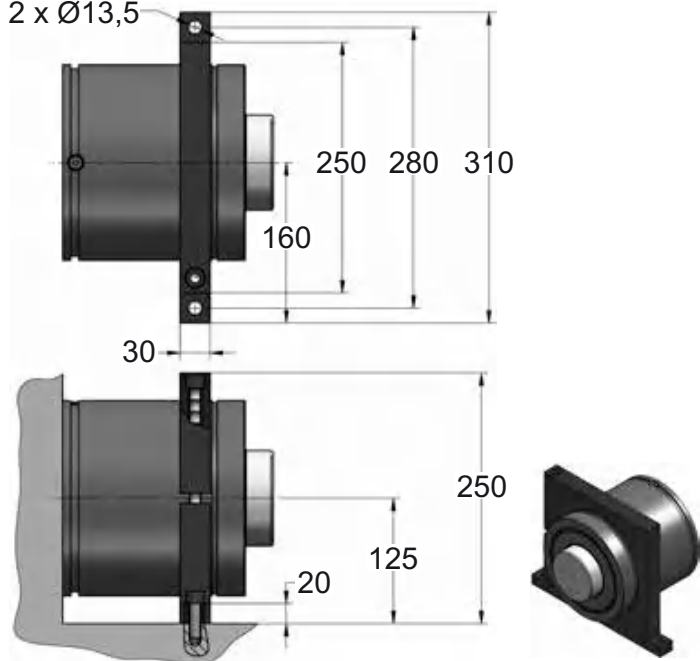

CODE	CW 20000 050	KIT S-XXXXXXX KIT C-XXXXXXX	D02-195	18 CG 1-Q
ENG	ORDER	GAS SPRING	REPAIR KIT	FLANGE
DEU	BESTELLUNG	GASDRUCKFEDER	ERSATZTEILSATZ	FLANSCHEN
FRA	COMMANDE	RESSORT À GAZ	KIT DE RÉPARATION	BRIDE
ITA	ORDINE	CILINDRO AD AZOTO	KIT DI MANUTENZIONE	FLANGE
ESP	PEDIDO	RESORTE DE GAS	KIT DE REPARACION	BRIDA
POR	PEDIDO	CILINDRO DE GÁS	KIT DE MANUTENÇÃO	FLANGE
				CHARGING ADAPTER
				LADEADAPTER
				RACCORD DE CHARGE
				ADATTATORE DI CARICO
				ADAPTADOR DE CARGA
				ADAPTADOR DE CARGA

